

**PHILIPPINE BIDDING
DOCUMENTS**

**Procurement of
INFRASTRUCTURE
PROJECTS**

Government of the Republic of the
Philippines

CITY GOVERNMENT OF NAGA

Name of Project/Contract:

Improvement of Multi-Purpose Bldg., Jolly Neighbors, Bgy. Sta.
Cruz

Project/Contract Reference Number: 009343-2024-01

**Sixth Edition
July 2020**

Preface

These Philippine Bidding Documents (PBDs) for the procurement of Infrastructure Projects (hereinafter referred to also as the “Works”) through Competitive Bidding have been prepared by the Government of the Philippines for use by all branches, agencies, departments, bureaus, offices, or instrumentalities of the government, including government-owned and/or -controlled corporations, government financial institutions, state universities and colleges, local government units, and autonomous regional government. The procedures and practices presented in this document have been developed through broad experience, and are for mandatory use in projects that are financed in whole or in part by the Government of the Philippines or any foreign government/foreign or international financing institution in accordance with the provisions of the 2016 revised Implementing Rules and Regulations (IRR) of Republic Act (RA) No. 9184.

The PBDs are intended as a model for admeasurements (unit prices or unit rates in a bill of quantities) types of contract, which are the most common in Works contracting.

The Bidding Documents shall clearly and adequately define, among others: (i) the objectives, scope, and expected outputs and/or results of the proposed contract; (ii) the eligibility requirements of Bidders; (iii) the expected contract duration; and (iv) the obligations, duties, and/or functions of the winning Bidder.

Care should be taken to check the relevance of the provisions of the PBDs against the requirements of the specific Works to be procured. If duplication of a subject is inevitable in other sections of the document prepared by the Procuring Entity, care must be exercised to avoid contradictions between clauses dealing with the same matter.

Moreover, each section is prepared with notes intended only as information for the Procuring Entity or the person drafting the Bidding Documents. They shall not be included in the final documents. The following general directions should be observed when using the documents:

- a. All the documents listed in the Table of Contents are normally required for the procurement of Infrastructure Projects. However, they should be adapted as necessary to the circumstances of the particular Project.
- b. Specific details, such as the “name of the Procuring Entity” and “address for bid submission,” should be furnished in the Instructions to Bidders, Bid Data Sheet, and Special Conditions of Contract. The final documents should contain neither blank spaces nor options.
- c. This Preface and the footnotes or notes in italics included in the Invitation to Bid, BDS, General Conditions of Contract, Special Conditions of Contract, Specifications, Drawings, and Bill of Quantities are not part of the text of the final document, although they contain instructions that the Procuring Entity should strictly follow.
- d. The cover should be modified as required to identify the Bidding Documents as to the names of the Project, Contract, and Procuring Entity, in addition to date of issue.
- e. Modifications for specific Procurement Project details should be provided in the Special Conditions of Contract as amendments to the Conditions of Contract. For easy completion, whenever reference has to be made to specific clauses in the Bid Data Sheet or Special Conditions of Contract, these terms shall be printed in bold typeface on Sections I (Instructions to Bidders) and III (General Conditions of Contract), respectively.

- f. For guidelines on the use of Bidding Forms and the procurement of Foreign-Assisted Projects, these will be covered by a separate issuance of the Government Procurement Policy Board.

TABLE OF CONTENTS

Glossary of Terms, Abbreviations, and Acronyms	5
Section I. Invitation to Bid	7
Section II. Instructions to Bidders	7
1. Scope of Bid.....	10
2. Funding Information	10
3. Bidding Requirements	10
4. Corrupt, Fraudulent, Collusive, Coercive, and Obstructive Practices	10
5. Eligible Bidders	10
6. Origin of Associated Goods	11
7. Subcontracts	11
8. Pre-Bid Conference	11
9. Clarification and Amendment of Bidding Documents	11
10. Documents Comprising the Bid: Eligibility and Technical Components.....	11
11. Documents Comprising the Bid: Financial Component	12
12. Alternative Bids	12
13. Bid Prices	12
14. Bid and Payment Currencies.....	12
15. Bid Security	13
16. Sealing and Marking of Bids	13
17. Deadline for Submission of Bids	13
18. Opening and Preliminary Examination of Bids.....	13
19. Detailed Evaluation and Comparison of Bids	13
20. Post Qualification	14
21. Signing of the Contract.....	14
Section III. Bid Data Sheet	15
Section IV. General Conditions of Contract.....	16
1. Scope of Contract.....	16
2. Sectional Completion of Works	16
3. Possession of Site	16
4. The Contractor's Obligations.....	16
5. Performance Security	16
6. Site Investigation Reports	17

7.	Warranty	17
8.	Liability of the Contractor	17
9.	Termination for Other Causes.....	17
10.	Dayworks	17
11.	Program of Work	18
12.	Instructions, Inspections and Audits.....	18
13.	Advance Payment	18
14.	Progress Payments	18
15.	Operating and Maintenance Manuals.....	18
Section V. Special Conditions of Contract		19
Section VI. Specifications.....		20
Section VII. Drawings.....		21
Section VIII. Bill of Quantities		22
Section IX. Checklist of Technical and Financial Documents		22

Glossary of Terms, Abbreviations, and Acronyms

ABC – Approved Budget for the Contract.

ARCC – Allowable Range of Contract Cost.

BAC – Bids and Awards Committee.

Bid – A signed offer or proposal to undertake a contract submitted by a bidder in response to and in consonance with the requirements of the bidding documents. Also referred to as Proposal and Tender. (2016 revised IRR, Section 5[c])

Bidder – Refers to a contractor, manufacturer, supplier, distributor and/or consultant who submits a bid in response to the requirements of the Bidding Documents. (2016 revised IRR, Section 5[d])

Bidding Documents – The documents issued by the Procuring Entity as the bases for bids, furnishing all information necessary for a prospective bidder to prepare a bid for the Goods, Infrastructure Projects, and/or Consulting Services required by the Procuring Entity. (2016 revised IRR, Section 5[e])

BIR – Bureau of Internal Revenue.

BSP – Bangko Sentral ng Pilipinas.

CDA – Cooperative Development Authority.

Consulting Services – Refer to services for Infrastructure Projects and other types of projects or activities of the GOP requiring adequate external technical and professional expertise that are beyond the capability and/or capacity of the GOP to undertake such as, but not limited to: (i) advisory and review services; (ii) pre-investment or feasibility studies; (iii) design; (iv) construction supervision; (v) management and related services; and (vi) other technical services or special studies. (2016 revised IRR, Section 5[i])

Contract – Refers to the agreement entered into between the Procuring Entity and the Supplier or Manufacturer or Distributor or Service Provider for procurement of Goods and Services; Contractor for Procurement of Infrastructure Projects; or Consultant or Consulting Firm for Procurement of Consulting Services; as the case may be, as recorded in the Contract Form signed by the parties, including all attachments and appendices thereto and all documents incorporated by reference therein.

Contractor – is a natural or juridical entity whose proposal was accepted by the Procuring Entity and to whom the Contract to execute the Work was awarded. Contractor as used in these Bidding Documents may likewise refer to a supplier, distributor, manufacturer, or consultant.

CPI – Consumer Price Index.

DOLE – Department of Labor and Employment.

DTI – Department of Trade and Industry.

Foreign-funded Procurement or Foreign-Assisted Project –Refers to procurement whose funding source is from a foreign government, foreign or international financing institution as specified in the Treaty or International or Executive Agreement. (2016 revised IRR, Section 5[b]).

GFI – Government Financial Institution.

GOCC –Government-owned and/or –controlled corporation.

Goods – Refer to all items, supplies, materials and general support services, except Consulting Services and Infrastructure Projects, which may be needed in the transaction of public businesses or in the pursuit of any government undertaking, project or activity, whether in the nature of equipment, furniture, stationery, materials for construction, or personal property of any kind, including non-personal or contractual services such as the repair and maintenance of equipment and furniture, as well as trucking, hauling, janitorial, security, and related or analogous services, as well as procurement of materials and supplies provided by the Procuring Entity for such services. The term “related” or “analogous services” shall include, but is not limited to, lease or purchase of office space, media advertisements, health maintenance services, and other services essential to the operation of the Procuring Entity. (2016 revised IRR, Section 5[r])

GOP – Government of the Philippines.

Infrastructure Projects – Include the construction, improvement, rehabilitation, demolition, repair, restoration or maintenance of roads and bridges, railways, airports, seaports, communication facilities, civil works components of information technology projects, irrigation, flood control and drainage, water supply, sanitation, sewerage and solid waste management systems, shore protection, energy/power and electrification facilities, national buildings, school buildings, hospital buildings, and other related construction projects of the government. Also referred to as civil works or works. (2016 revised IRR, Section 5[u])

LGUs – Local Government Units.

NFCC – Net Financial Contracting Capacity.

NGA – National Government Agency.

PCAB – Philippine Contractors Accreditation Board.

PhilGEPS - Philippine Government Electronic Procurement System.

Procurement Project – refers to a specific or identified procurement covering goods, infrastructure project or consulting services. A Procurement Project shall be described, detailed, and scheduled in the Project Procurement Management Plan prepared by the agency which shall be consolidated in the procuring entity's Annual Procurement Plan. (GPPB Circular No. 06-2019 dated 17 July 2019)

PSA – Philippine Statistics Authority.

SEC – Securities and Exchange Commission.

SLCC – Single Largest Completed Contract.

UN – United Nations.

Section I. Invitation to Bid

INVITATION TO BID

FOR THE

CONSTRUCTION OF

INFRASTRUCTURE PROJECTS

- The City Government of Naga, intends to apply the sum of **Two Million Four Hundred Thousand (P 2,400,000.00)** Pesos being the Approved Budget for the Contract (ABC) for the construction of the following infrastructure project:

#	Contract Reference Number	Name of Project and Location	Approved Budget for the Contract (ABC)	Contract Duration (calendar days)	Equipment Required	Source of Fund	Cost of Bid Documents
1	009315-2024-01	RC Pipe & Cross Drainage, Zone 1 Sitio San Jose, Bgy. Carolina	480,000.00	45	Concrete mixer	Barangay Support Fund	500.00
2	009466-2024-01	Drainage & Concrete Pavement, Pagdahicon, Bgy. Mabolo	480,000.00	45	Concrete mixer, compactor, welding machine	Barangay Support Fund	500.00
3	009345-2024-01	CHB Box Type Drainage, Ramon Diaz St., Bgy. Del Rosario	480,000.00	60	Concrete	Barangay Support Fund	500.00
4	009377-2024-01	RC Pipe Drainage, Villa Robredo, Sabang	480,000.00	45	Concrete mixer	Barangay Support Fund	500.00
5	009343-2024-01	Improvement of Multi-Purpose Bldg., Jolly Neighbors, Bgy. Sta. Cruz	480,000.00	60	Welding machine	Barangay Support Fund	500.00

The envelope for civil works bid documents should be enclosed in a Blue Expanding Envelope. Bids received over the ABC shall be automatically rejected at the bid opening.

- The City Government of Naga now invites bids for the above Procurement Project. Completion of the Works is required within the required contract duration. Bidders should have completed a contract similar to the Project. The description of an eligible bidder is contained in the Bidding Documents, particularly, in Section II (Instructions to Bidders).

3. Bidding will be conducted through open competitive bidding procedures using non-discretionary “pass/fail” criterion as specified in the 2016 revised Implementing Rules and Regulations (IRR) of Republic Act (RA) No. 9184.
4. Interested bidders may obtain further information from the City Government of Naga and inspect the Bidding Documents at the address given below from 8:00AM to 5:00PM.
5. A complete set of Bidding Documents may be acquired by interested bidders on **Friday, July 19, 2024, to Thursday, August 8, 2024**, from the BAC Secretariat, Room 208 Second Floor, City Hall Building, City Hall Compound and www.naga.gov.ph and www.philgeps.gov.ph; and upon payment of the applicable fee for the Bidding Documents, pursuant to the latest Guidelines issued by the GPPB, as stated above. The Procuring Entity shall allow the bidder to present its proof of payment for the fees will be presented in person.
6. The City Government of Naga will hold a **Pre-Bid Conference** on **Monday, July 29, 2024**, 3:00PM at the City Procurement Office, Ground Floor, Main Building, City Hall Compound, which shall be open to prospective bidders.
7. Bids must be duly received by the BAC Secretariat through manual submission at the City Procurement Office, Room 107, Ground Floor, Main Building, City Hall Compound on or before 9:00AM on **Thursday, August 8, 2024**. **Late bids shall not be accepted.**
8. All bids must be accompanied by a bid security in any of the acceptable forms and in the amount stated in **ITB** Clause 16.
9. **Bid opening** shall be on **Thursday, August 8, 2024**, 10:00AM at the City Procurement Office, Ground Floor, Main Building, City Hall Compound. Bids will be opened in the presence of the bidders’ representatives who choose to attend the activity.
10. Additional information:
 - a) An Annual Registration Fee of Three Thousand (P 3,000.00) Pesos is required.
 - b) Forms in the PBD should be used in submitting proposals and should remain unaltered.
 - c) Prospective Bidders are strongly encouraged to order or download the electronic copy of the Bidding Documents from the PhilGEPS website, for them to be included in the Document Request List (DRL) of the project.
11. The City Government of Naga reserves the right to reject any and all bids, declare a failure of bidding, or not award the contract at any time prior to contract award in accordance with Sections 35.6 and 41 of the 2016 revised Implementing Rules and Regulations (IRR) of RA No. 9184, without thereby incurring any liability to the affected bidder or bidders.
12. For further information, please refer to:

Mr. FRANCISCO M. MENDOZA

City Budget Officer and BAC Chairperson

1st Floor City Hall Building, City Hall Compound,

J. Miranda Avenue, Concepcion Pequeña, Naga City 4400

Mobile Number: +639209450237

Email address: bac@naga.gov.ph, frankmm@naga.gov.ph

Website: www.naga.gov.ph

13. For downloading of bidding documents, you may visit the following websites: www.philgeps.gov.ph / www.naga.gov.ph

Date of Issue: July 19, 2024, to August 8, 2024



FRANCISCO M. MENDOZA
Chairperson, Bids and Awards Committee

Section II. Instructions to Bidders

1. Scope of Bid

The Procuring Entity, City Government of Naga invites Bids for the construction of Improvement of Multi-Purpose Bldg, Jolly Neighbors, Bgy. Sta. Cruz, with Project/Contract Reference Number: 009343-2024-01.

The Procurement Project (referred to herein as “Project”) is for the construction of Works, as described in Section VI (Specifications).

2. Funding Information

2.1. The GOP through the source of funding as indicated below for BSF in the amount of Four Hundred Eighty Thousand (P 480,000.00) Pesos.

2.2. The source of funding is: Barangay Support Fund.

3. Bidding Requirements

The Bidding for the Project shall be governed by all the provisions of RA No. 9184 and its 2016 revised IRR, including its Generic Procurement Manual and associated policies, rules and regulations as the primary source thereof, while the herein clauses shall serve as the secondary source thereof.

Any amendments made to the IRR and other GPPB issuances shall be applicable only to the ongoing posting, advertisement, or invitation to bid by the BAC through the issuance of a supplemental or bid bulletin.

The Bidder, by the act of submitting its Bid, shall be deemed to have inspected the site, determined the general characteristics of the contracted Works and the conditions for this Project, such as the location and the nature of the work; (b) climatic conditions; (c) transportation facilities; (c) nature and condition of the terrain, geological conditions at the site communication facilities, requirements, location and availability of construction aggregates and other materials, labor, water, electric power and access roads; and (d) other factors that may affect the cost, duration and execution or implementation of the contract, project, or work and examine all instructions, forms, terms, and project requirements in the Bidding Documents.

4. Corrupt, Fraudulent, Collusive, Coercive, and Obstructive Practices

The Procuring Entity, as well as the Bidders and Contractors, shall observe the highest standard of ethics during the procurement and execution of the contract. They or through an agent shall not engage in corrupt, fraudulent, collusive, coercive, and obstructive practices defined under Annex “I” of the 2016 revised IRR of RA No. 9184 or other integrity violations in competing for the Project.

5. Eligible Bidders

- 5.1. Only Bids of Bidders found to be legally, technically, and financially capable will be evaluated.
- 5.2. The Bidder must have an experience of having completed a Single Largest Completed Contract (SLCC) that is similar to this Project, equivalent to at least fifty percent (50%) of the ABC adjusted, if necessary, by the Bidder to current prices using the PSA's CPI, except under conditions provided for in Section 23.4.2.4 of the 2016 revised IRR of RA No. 9184.

A contract is considered to be "similar" to the contract to be bid if it has the major categories of work stated in the **BDS**.

- 5.3. For Foreign-funded Procurement, the Procuring Entity and the foreign government/foreign or international financing institution may agree on another track record requirement, as specified in the Bidding Document prepared for this purpose.
- 5.4. The Bidders shall comply with the eligibility criteria under Section 23.4.2 of the 2016 IRR of RA No. 9184.

6. Origin of Associated Goods

There is no restriction on the origin of Goods other than those prohibited by a decision of the UN Security Council taken under Chapter VII of the Charter of the UN.

7. Subcontracts

- 7.1. The Bidder may subcontract portions of the Project to the extent allowed by the Procuring Entity as stated herein, but in no case more than fifty percent (50%) of the Project.

The Procuring Entity has prescribed that: Subcontracting is not allowed.

8. Pre-Bid Conference

The Procuring Entity will hold a pre-bid conference for this Project on the specified date and time and either at its physical address City Procurement Office, Ground Floor, City Hall Building, City Hall Compound, Naga City, as indicated in paragraph 6 of the **IB**.

9. Clarification and Amendment of Bidding Documents

Prospective bidders may request for clarification on and/or interpretation of any part of the Bidding Documents. Such requests must be in writing and received by the Procuring Entity, either at its given address or through electronic mail indicated in the **IB**, at least ten (10) calendar days before the deadline set for the submission and receipt of Bids.

10. Documents Comprising the Bid: Eligibility and Technical Components

- 10.1. The first envelope shall contain the eligibility and technical documents of the Bid as specified in **Section IX. Checklist of Technical and Financial Documents**.

- 10.2. If the eligibility requirements or statements, the bids, and all other documents for submission to the BAC are in foreign language other than English, it must be accompanied by a translation in English, which shall be authenticated by the appropriate Philippine foreign service establishment, post, or the equivalent office having jurisdiction over the foreign bidder's affairs in the Philippines. For Contracting Parties to the Apostille Convention, only the translated documents shall be authenticated through an apostille pursuant to GPPB Resolution No. 13-2019 dated 23 May 2019. The English translation shall govern, for purposes of interpretation of the bid.
- 10.3. A valid special PCAB License in case of Joint Ventures, and registration for the type and cost of the contract for this Project. Any additional type of Contractor license or permit shall be indicated in the **BDS**.
- 10.4. A List of Contractor's key personnel (e.g., Project Manager, Project Engineers, Materials Engineers, and Foremen) assigned to the contract to be bid, with their complete qualification and experience data shall be provided. These key personnel must meet the required minimum years of experience set in the **BDS**.
- 10.5. A List of Contractor's major equipment units, which are owned, leased, and/or under purchase agreements, supported by proof of ownership, certification of availability of equipment from the equipment lessor/vendor for the duration of the project, as the case may be, must meet the minimum requirements for the contract set in the **BDS**.

11. Documents Comprising the Bid: Financial Component

- 11.1. The second bid envelope shall contain the financial documents for the Bid as specified in **Section IX. Checklist of Technical and Financial Documents**.
- 11.2. Any bid exceeding the ABC indicated in paragraph 1 of the **IB** shall not be accepted.
- 11.3. For Foreign-funded procurement, a ceiling may be applied to bid prices provided the conditions are met under Section 31.2 of the 2016 revised IRR of RA No. 9184.

12. Alternative Bids

Bidders shall submit offers that comply with the requirements of the Bidding Documents, including the basic technical design as indicated in the drawings and specifications. Unless there is a value engineering clause in the **BDS**, alternative Bids shall not be accepted.

13. Bid Prices

All bid prices for the given scope of work in the Project as awarded shall be considered as fixed prices, and therefore not subject to price escalation during contract implementation, except under extraordinary circumstances as determined by the NEDA and approved by the GPPB pursuant to the revised Guidelines for Contract Price Escalation guidelines.

14. Bid and Payment Currencies

- 14.1. Bid prices may be quoted in the local currency or tradeable currency accepted by the BSP at the discretion of the Bidder. However, for purposes of bid evaluation, Bids denominated in foreign currencies shall be converted to Philippine currency based on the exchange rate as published in the BSP reference rate bulletin on the day of the bid opening.
- 14.2. Payment of the contract price shall be made in: Philippine Pesos.

15. Bid Security

- 15.1. The Bidder shall submit a Bid Securing Declaration or any form of Bid Security in the amount indicated in the **BDS**, which shall be not less than the percentage of the ABC in accordance with the schedule in the **BDS**.
- 15.2. The Bid and bid security shall be valid until 120 calendar days. Any bid not accompanied by an acceptable bid security shall be rejected by the Procuring Entity as non-responsive.

16. Sealing and Marking of Bids

Each Bidder shall submit one copy of the first and second components of its Bid.

The Procuring Entity may request additional hard copies and/or electronic copies of the Bid. However, failure of the Bidders to comply with the said request shall not be a ground for disqualification.

If the Procuring Entity allows the submission of bids through online submission to the given website or any other electronic means, the Bidder shall submit an electronic copy of its Bid, which must be digitally signed. An electronic copy that cannot be opened or is corrupted shall be considered non-responsive and, thus, automatically disqualified.

17. Deadline for Submission of Bids

The Bidders shall submit on the specified date and time and either at its physical address or through online submission as indicated in paragraph 7 of the **IB**.

18. Opening and Preliminary Examination of Bids

- 18.1. The BAC shall open the Bids in public at the time, on the date, and at the place specified in paragraph 9 of the **IB**. The Bidders' representatives who are present shall sign a register evidencing their attendance. In case videoconferencing, webcasting or other similar technologies will be used, attendance of participants shall likewise be recorded by the BAC Secretariat.

In case the Bids cannot be opened as scheduled due to justifiable reasons, the rescheduling requirements under Section 29 of the 2016 revised IRR of RA No. 9184 shall prevail.

- 18.2. The preliminary examination of Bids shall be governed by Section 30 of the 2016 revised IRR of RA No. 9184.

19. Detailed Evaluation and Comparison of Bids

- 19.1. The Procuring Entity's BAC shall immediately conduct a detailed evaluation of all Bids rated "passed" using non-discretionary pass/fail criteria. The BAC shall consider the conditions in the evaluation of Bids under Section 32.2 of 2016 revised IRR of RA No. 9184.
- 19.2. If the Project allows partial bids, all Bids and combinations of Bids as indicated in the **BDS** shall be received by the same deadline and opened and evaluated simultaneously so as to determine the Bid or combination of Bids offering the lowest calculated cost to the Procuring Entity. Bid Security as required by **ITB** Clause 15 shall be submitted for each contract (lot) separately.
- 19.3. In all cases, the NFCC computation pursuant to Section 23.4.2.6 of the 2016 revised IRR of RA No. 9184 must be sufficient for the total of the ABCs for all the lots participated in by the prospective Bidder.

20. Post Qualification

Within a non-extendible period of five (5) calendar days from receipt by the Bidder of the notice from the BAC that it submitted the Lowest Calculated Bid, the Bidder shall submit its latest income and business tax returns filed and paid through the BIR Electronic Filing and Payment System (eFPS), and other appropriate licenses and permits required by law and stated in the **BDS**.

21. Signing of the Contract

The documents required in Section 37.2 of the 2016 revised IRR of RA No. 9184 shall form part of the Contract. Additional Contract documents are indicated in the **BDS**.

Section III. Bid Data Sheet

Bid Data Sheet

ITB Clause	
5.2	<p>For this purpose, contracts similar to the Project refer to contracts which have the same major categories of work, which shall be:</p> <p style="background-color: yellow;">Engineering and construction structures that are similar or related.</p>
10.4	<p>The key personnel must meet the required minimum years of experience set below:</p> <p><u>Key Personnel General Experience Relevant Experience</u></p> <p>Project Manager, Project Engineer, Foreman, licensed Construction Safety and Health Officer, Materials Engineer, and workers</p>
10.5	<p>The minimum major equipment requirements are the following:</p> <p style="background-color: yellow;">Welding Machine</p>
15.1	<p>The bid security shall be in the form of a Bid Securing Declaration or any of the following forms and amounts:</p> <p style="margin-left: 20px;">a. The amount of not less than P 9,600.00 [Insert two percent (2%) of ABC], if bid security is in cash, cashier's/manager's check, bank draft/guarantee or irrevocable letter of credit;</p> <p style="margin-left: 20px;">b. The amount of not less than P 24,000.00 [Insert five percent (5%) of ABC] if bid security is in Surety Bond.</p>
21	<p>Additional contract documents relevant to the Project that may be required by existing laws and/or the Procuring Entity, such as construction schedule and S-curve, manpower schedule, construction methods, equipment utilization schedule, construction safety and health program approved by the DOLE, and other acceptable tools of project scheduling.</p>

Section IV. General Conditions of Contract

1. Scope of Contract

This Contract shall include all such items, although not specifically mentioned, that can be reasonably inferred as being required for its completion as if such items were expressly mentioned herein. All the provisions of RA No. 9184 and its 2016 revised IRR, including the Generic Procurement Manual, and associated issuances, constitute the primary source for the terms and conditions of the Contract, and thus, applicable in contract implementation. Herein clauses shall serve as the secondary source for the terms and conditions of the Contract.

This is without prejudice to Sections 74.1 and 74.2 of the 2016 revised IRR of RA No. 9184 allowing the GPPB to amend the IRR, which shall be applied to all procurement activities, the advertisement, posting, or invitation of which were issued after the effectivity of the said amendment.

2. Sectional Completion of Works

If sectional completion is specified in the **Special Conditions of Contract (SCC)**, references in the Conditions of Contract to the Works, the Completion Date, and the Intended Completion Date shall apply to any Section of the Works (other than references to the Completion Date and Intended Completion Date for the whole of the Works).

3. Possession of Site

3.1 The Procuring Entity shall give possession of all or parts of the Site to the Contractor based on the schedule of delivery indicated in the **SCC**, which corresponds to the execution of the Works. If the Contractor suffers delay or incurs cost from failure on the part of the Procuring Entity to give possession in accordance with the terms of this clause, the Procuring Entity's Representative shall give the Contractor a Contract Time Extension and certify such sum as fair to cover the cost incurred, which sum shall be paid by Procuring Entity.

3.2 If possession of a portion is not given by the above date, the Procuring Entity will be deemed to have delayed the start of the relevant activities. The resulting adjustments in contract time to address such delay may be addressed through contract extension provided under Annex "E" of the 2016 revised IRR of RA No. 9184.

4. The Contractor's Obligations

The Contractor shall employ the key personnel named in the Schedule of Key Personnel indicating their designation, in accordance with **ITB** Clause 10.3 and specified in the **BDS**, to carry out the supervision of the Works.

The Procuring Entity will approve any proposed replacement of key personnel only if their relevant qualifications and abilities are equal to or better than those of the personnel listed in the Schedule.

5. Performance Security

- 5.1. Within ten (10) calendar days from receipt of the Notice of Award from the Procuring Entity but in no case later than the signing of the contract by both parties, the successful Bidder shall furnish the performance security in any of the forms prescribed in Section 39 of the 2016 revised IRR.
- 5.2. The Contractor, by entering into the Contract with the Procuring Entity, acknowledges the right of the Procuring Entity to institute action pursuant to RA No. 3688 against any subcontractor be they an individual, firm, partnership, corporation, or association supplying the Contractor with labor, materials and/or equipment for the performance of this Contract.

6. Site Investigation Reports

The Contractor, in preparing the Bid, shall rely on any Site Investigation Reports referred to in the **SCC** supplemented by any information obtained by the Contractor.

7. Warranty

- 7.1. In case the Contractor fails to undertake the repair works under Section 62.2.2 of the 2016 revised IRR, the Procuring Entity shall forfeit its performance security, subject its property(ies) to attachment or garnishment proceedings, and perpetually disqualify it from participating in any public bidding. All payables of the GOP in his favor shall be offset to recover the costs.
- 7.2. The warranty against Structural Defects/Failures, except that occasioned-on force majeure, shall cover the period from the date of issuance of the Certificate of Final Acceptance by the Procuring Entity. Specific duration of the warranty is found in the **SCC**.

8. Liability of the Contractor

Subject to additional provisions, if any, set forth in the **SCC**, the Contractor's liability under this Contract shall be as provided by the laws of the Republic of the Philippines.

If the Contractor is a joint venture, all partners to the joint venture shall be jointly and severally liable to the Procuring Entity.

9. Termination for Other Causes

Contract termination shall be initiated in case it is determined prima facie by the Procuring Entity that the Contractor has engaged, before, or during the implementation of the contract, in unlawful deeds and behaviors relative to contract acquisition and implementation, such as, but not limited to corrupt, fraudulent, collusive, coercive, and obstructive practices as stated in **ITB** Clause 4.

10. Dayworks

Subject to the guidelines on Variation Order in Annex "E" of the 2016 revised IRR of RA No. 9184, and if applicable as indicated in the **SCC**, the Dayworks rates in the Contractor's Bid shall be used for small additional amounts of work only when the Procuring Entity's

Representative has given written instructions in advance for additional work to be paid for in that way.

11. Program of Work

- 11.1. The Contractor shall submit to the Procuring Entity's Representative for approval the said Program of Work showing the general methods, arrangements, order, and timing for all the activities in the Works. The submissions of the Program of Work are indicated in the **SCC**.
- 11.2. The Contractor shall submit to the Procuring Entity's Representative for approval an updated Program of Work at intervals no longer than the period stated in the **SCC**. If the Contractor does not submit an updated Program of Work within this period, the Procuring Entity's Representative may withhold the amount stated in the **SCC** from the next payment certificate and continue to withhold this amount until the next payment after the date on which the overdue Program of Work has been submitted.

12. Instructions, Inspections and Audits

The Contractor shall permit the GOP or the Procuring Entity to inspect the Contractor's accounts and records relating to the performance of the Contractor and to have them audited by auditors of the GOP or the Procuring Entity, as may be required.

13. Advance Payment

The Procuring Entity shall, upon a written request of the Contractor which shall be submitted as a Contract document, make an advance payment to the Contractor in an amount not exceeding fifteen percent (15%) of the total contract price, to be made in lump sum, or at the most two installments according to a schedule specified in the **SCC**, subject to the requirements in Annex "E" of the 2016 revised IRR of RA No. 9184.

14. Progress Payments

The Contractor may submit a request for payment for Work accomplished. Such requests for payment shall be verified and certified by the Procuring Entity's Representative/Project Engineer. Except as otherwise stipulated in the **SCC**, materials and equipment delivered on the site but not completely put in place shall not be included for payment.

15. Operating and Maintenance Manuals

- 15.1. If required, the Contractor will provide "as built" Drawings and/or operating and maintenance manuals as specified in the **SCC**.
- 15.2. If the Contractor does not provide the Drawings and/or manuals by the dates stated above, or they do not receive the Procuring Entity's Representative's approval, the Procuring Entity's Representative may withhold the amount stated in the **SCC** from payments due to the Contractor.

Section V. Special Conditions of Contract

Special Conditions of Contract

GCC Clause	
7.2	<p>[In case of permanent structures, such as buildings of types 4 and 5 as classified under the National Building Code of the Philippines and other structures made of steel, iron, or concrete which comply with relevant structural codes (e.g., DPWH Standard Specifications), such as, but not limited to, steel/concrete bridges, flyovers, aircraft movement areas, ports, dams, tunnels, filtration and treatment plants, sewerage systems, power plants, transmission and communication towers, railway system, and other similar permanent structures:] Fifteen (15) years.</p> <p>[In case of semi-permanent structures, such as buildings of types 1, 2, and 3 as classified under the National Building Code of the Philippines, concrete/asphalt roads, concrete river control, drainage, irrigation lined canals, river landing, deep wells, rock causeway, pedestrian overpass, and other similar semi-permanent structures:] Five (5) years.</p> <p>[In case of other structures, such as bailey and wooden bridges, shallow wells, spring developments, and other similar structures:] Two (2) years.</p>
10	Dayworks are applicable at the rate shown in the Contractor's original Bid.
11.1	The Contractor shall submit the Program of Work to the Procuring Entity's Representative immediately upon delivery of the Notice of Award.
13	The amount of the advance payment is P 72,000.00 Pesos, as percentage of the contract price that shall not exceed 15% of the total contract price and schedule of payment].

Section VI. Specifications

Section VII. Drawings

PROJECT ID.NO : 009343-2024-01

PROPOSED IMPROVEMENT OF MULTI-PURPOSE BLDG

LOCATION: JOLLY NEIGHBORS, BARANGAY STA. CRUZ, NAGA CITY



PERSPECTIVE



LOCATION MAP

<p>REPUBLIC OF THE PHILIPPINES OFFICE OF THE CITY ENGINEER CITY OF NAGA</p> 	<p>PROJECT TITLE</p> <p>PROPOSED IMPROVEMENT OF MULTI-PURPOSE BLDG</p>	<p>CHECKED BY:</p> <p>BRET OWEN S. TALAGTAG ENGINEER I</p>	<p>RECOMMENDED BY:</p> <p>EMMEL M. ADAQUE ENGINEER III</p>	<p>APPROVED BY:</p> <p>ALEXANDER N. CANING ACTING CITY ENGINEER</p>	<p>NELSON S. LEGACION CITY MAYOR</p>	<p>CAD BY: ALVAR RONALD A. PUNZALAN</p>	<p>SHEET NO. A1 A3</p>
	<p>LOCATION: JOLLY NEIGHBORS, BARANGAY DINAGA, NAGA CITY</p>						

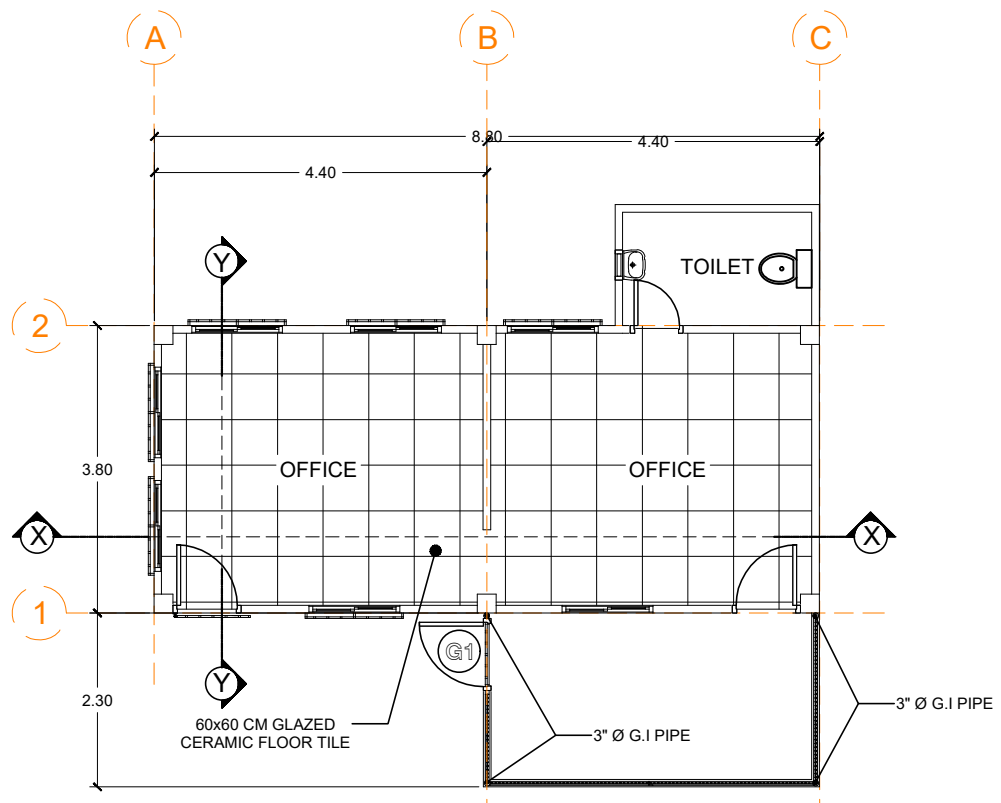

FLOOR PLAN
SCALE 1:100m

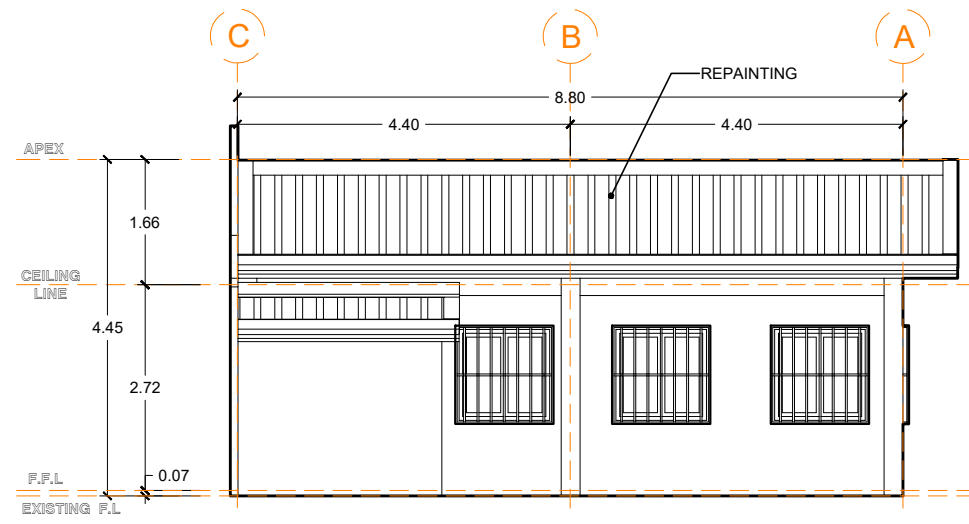

REAR ELEVATION
SCALE 1:100m

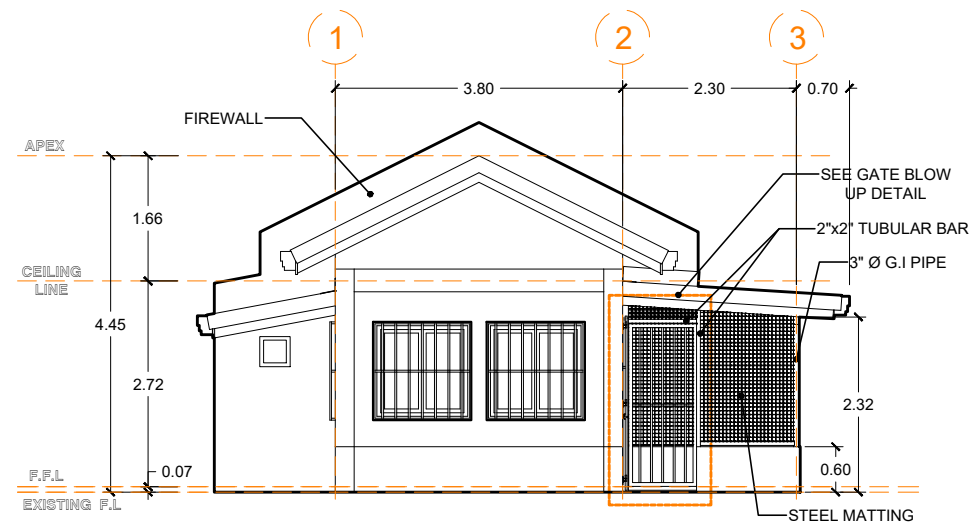

LEFT-SIDE ELEVATION
SCALE 1:100m

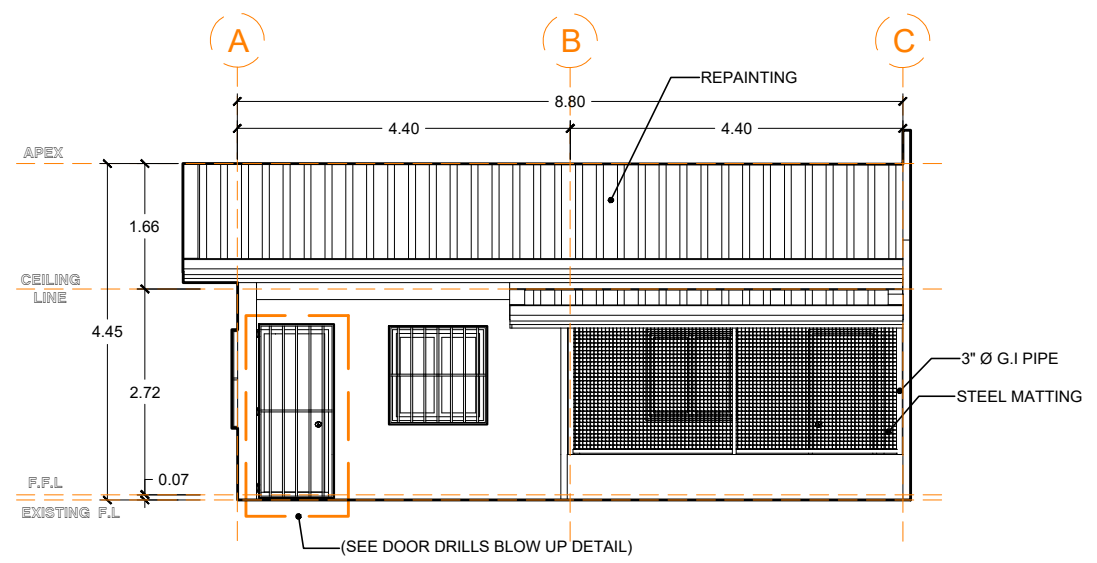

FRONT ELEVATION
SCALE 1:100m

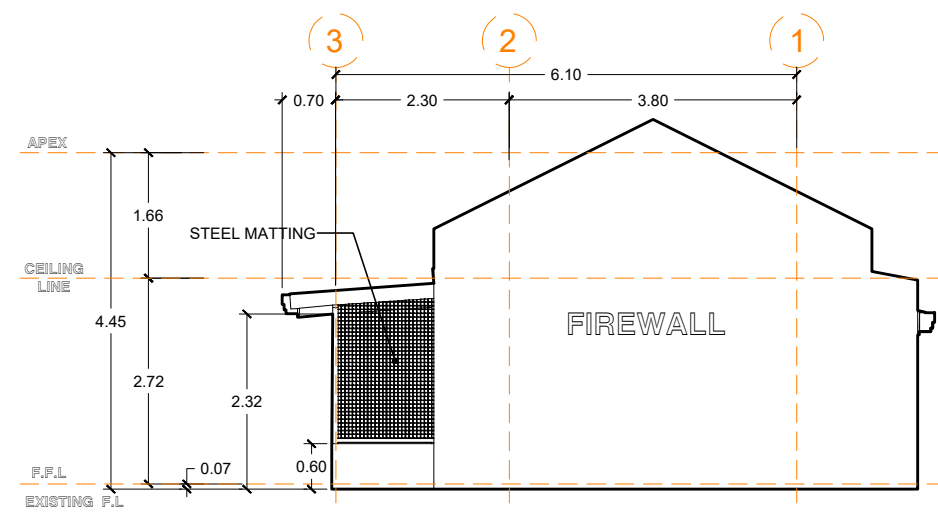

RIGHT-SIDE ELEVATION
SCALE 1:100m

REPUBLIC OF THE PHILIPPINES OFFICE OF THE CITY ENGINEER CITY OF NAGA	PROJECT TITLE	CHECKED BY:	RECOMMENDED BY:	APPROVED BY:	CAD BY:	SHEET NO.
	PROPOSED IMPROVEMENT OF MULTI-PURPOSE BLDG LOCATION: JOLLY NEIGHBORS, BARANGAY DINAGA, NAGA CITY	BRET OWEN S. TALAGTAG ENGINEER I	EMMEL M. ADAQUE ENGINEER III	ALEXANDER N. CANING ACTING CITY ENGINEER	NELSON S. LEGACION CITY MAYOR	

A2
A3

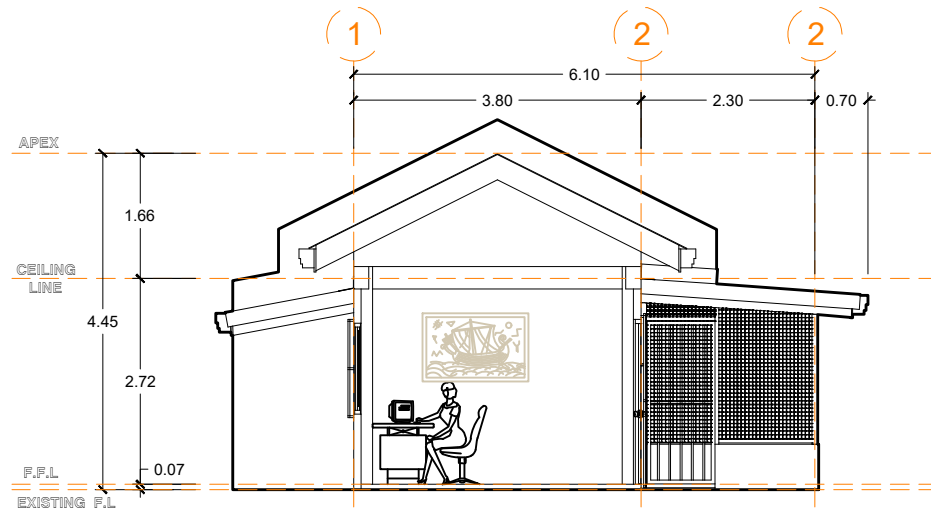

SECTION THRU Y
SCALE 1:100m

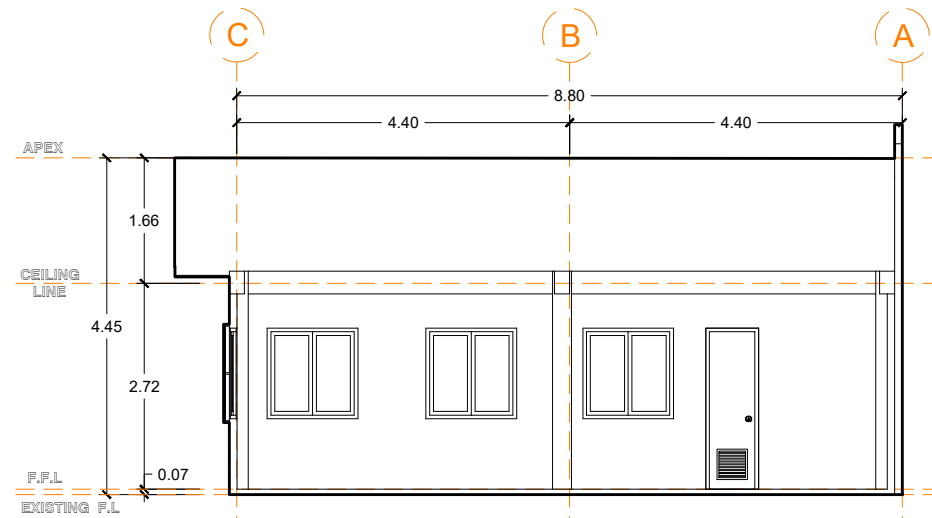

SECTION THRU X
SCALE 1:100m

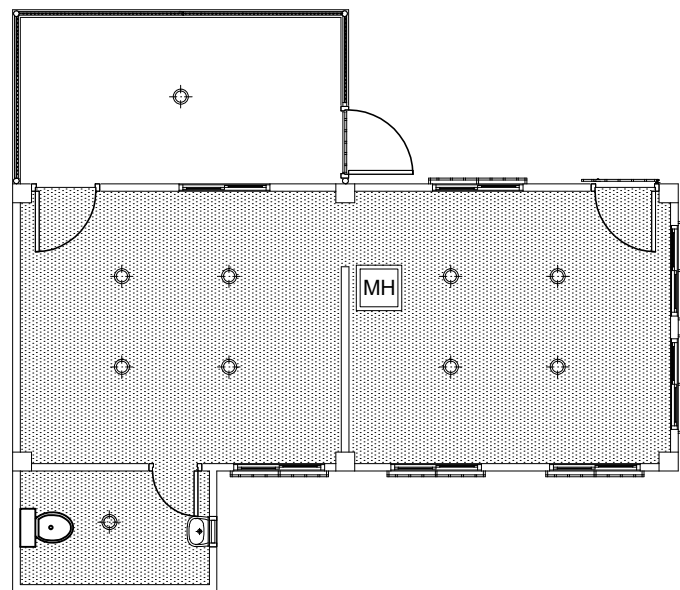

REFLECTED CEILING PLAN
SCALE 1:100m

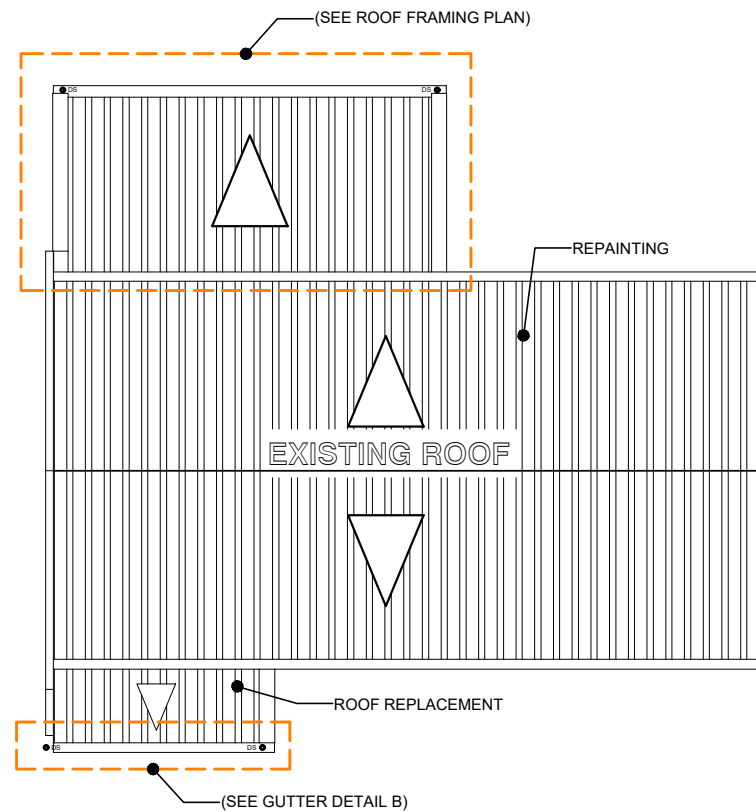

ROOF PLAN
SCALE 1:100m

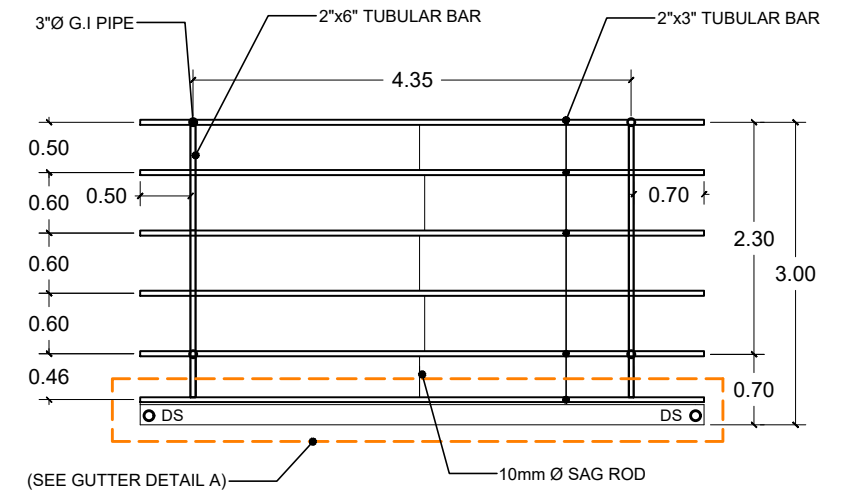

ROOF FRAMING PLAN
SCALE 1:75m

REPUBLIC OF THE PHILIPPINES OFFICE OF THE CITY ENGINEER CITY OF NAGA	PROJECT TITLE PROPOSED IMPROVEMENT OF MULTI-PURPOSE BLDG	CHECKED BY: BRET OWEN S. TALAGTAG ENGINEER I	RECOMMENDED BY: EMMEL M. ADAQUE ENGINEER III	APPROVED BY: ALEXANDER N. CANING ACTING CITY ENGINEER	APPROVED BY: NELSON S. LEGACION CITY MAYOR	CAD BY: ALVAR RONALD A. PUNZALAN	SHEET NO. A3 A3
	LOCATION: JOLLY NEIGHBORS, BARANGAY DINAGA, NAGA CITY						

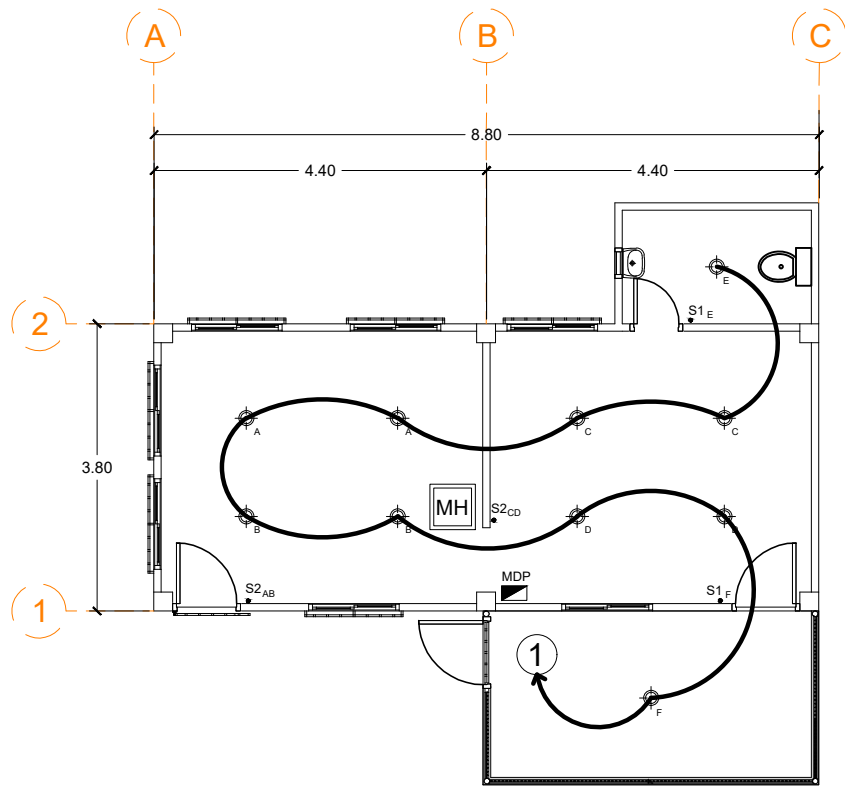

LIGHTING LAYOUT
SCALE 1:100m

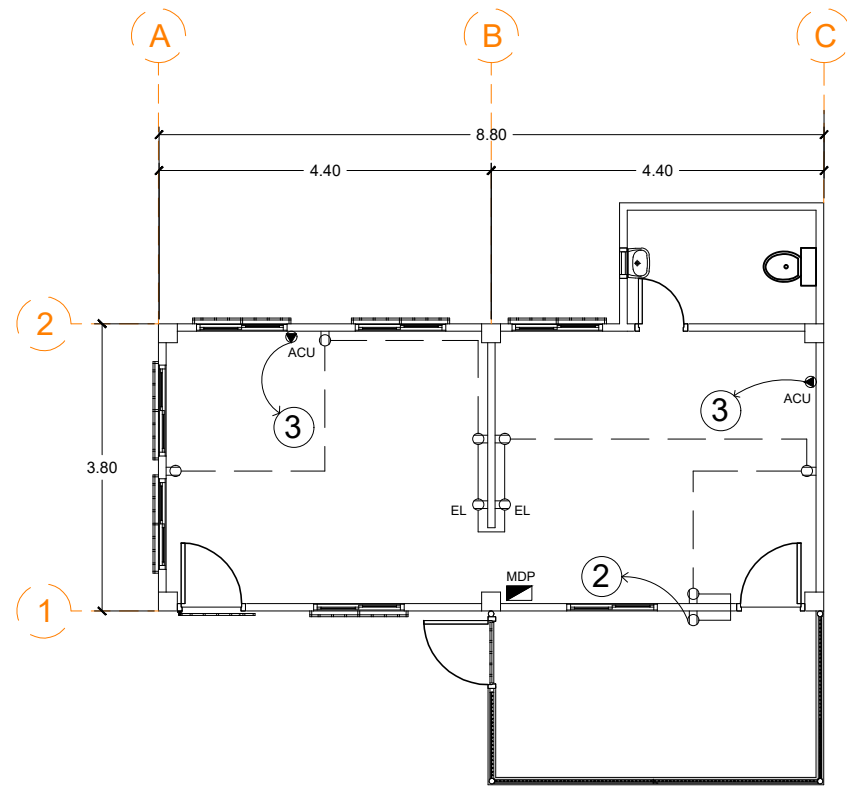

POWER LAYOUT
SCALE 1:100m

1. ALL ELECTRICAL WORKS AND INSTALLATION HEREIN SHALL BE DONE IN ACCORDANCE WITH THE PROVISIONS OF THE LATEST ISSUE OF THE PHILIPPINE ELECTRICAL CODE, THE RULES AND REGULATION IN THE MUNICIPALITY OF PLU AND THE POWER AND TELECOMMUNICATION COMPANIES AND THE REPUBLIC ACT 7920 APPLIED IN THE MUNICIPALITY OF NAGA
2. THE ELECTRICAL CONTRACTOR SHALL SECURE ALL WIRING PERMITS AND ALL FEES REQUIRED FOR THE WORK SHALL FINISH THE OWNER THROUGH THE ENGINEERS FINAL CERTIFICATE OF ELECTRICAL INSPECTION AND APPROVAL FROM THE PROPER GOVERNMENT AUTHORITIES FOR COMPLETE WORK.
3. ALL MATERIALS AND EQUIPMENT TO BE USED SHALL BE BRAND NEW AND APPROVED TYPE AS TO LOCATION OF THE PHILIPPINE COUNCIL.
4. THE ELECTRICAL CONTRACTOR SHALL REFER TO THE ARCHITECTURAL DRAWING FOR THE EXACT LOCATION AND MOUNTING HEIGHTS OF ALL WIRING DEVICES AND ELECTRICAL FIXTURES.
5. CIRCUIT BREAKERS SHALL BE BOLT-ON-TYPE AND OF THE MAGNETIC THERMAL TYPE COMMON WITH RATINGS AND NUMBER OF POLES AS INDICATED IN THE DRAWINGS.
6. MINIMUM SIZE OF ELECTRICAL CONDUCTOR AND CONDUITS WHERE NOT INDICATED IN THE PLAN SHALL BE 3.50mm² Ø TYPE THHN AND 20mmØ RESPECTIVELY.
7. THE ELECTRICAL CONTRACTOR REQUIRED VISITING THE SITE TO A CERTAIN HIMSELF TO THE LOCAL CONDITION THAT MAY AFFECT HIS WORK.
8. THE ELECTRICAL WORKS SHALL BE DONE UNDER THE DIRECT AND IMMEDIATE SUPERVISION OF A DULY QUALIFIED LICENSED ELECTRICAL ENGINEER OR MASTER ELECTRICIAN.
9. THE ELECTRICAL REQUIRED TO CONDUCT GROUNDING TEST INSULATION TEST PRIOR TO COMPLETION OF THE PROJECT.
10. WIRE MUST BE CONTINUOUS TO THE OUTLET WITHOUT SPICE THROUGHOUT THE CONDUIT BODY. SPLICES ARE PERMITTED ONLY AT OUTLET BOXES FULL OR JUNCTION BOXES WHERE THE SPLICE, OTHERWISE PERMANENTLY ACCESSIBLE.
11. ALL METAL FRAMES SHALL BE PROPERLY ADEQUATELY GROUNDED.
12. POWER SOURCES SHALL BE 230V 10 2W GROUND 60HZ SYSTEM.
13. WIRING METHOD SHALL BE COLOR AS FOLLOW:

a. PHASE A	BLACK
b. PHASE B	WHITE (NEUTRAL)
c. GROUND	GREEN
d. LIGHTING CONTROLLED	1.40m FROM F.F.L.
e. RECEPTACLE	0.30m FROM F.F.L.
f. PANEL BOARD	1.80m FROM F.F.L.

GENERAL NOTES

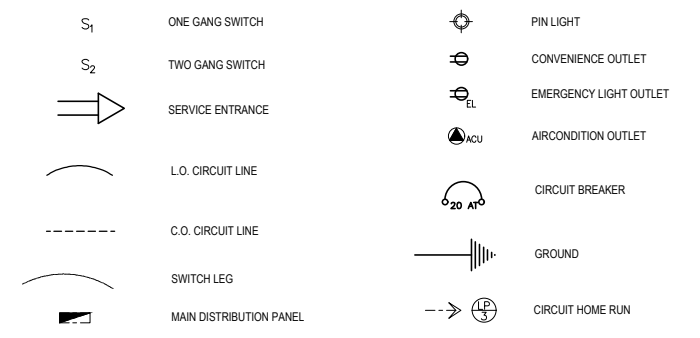

LEGEND

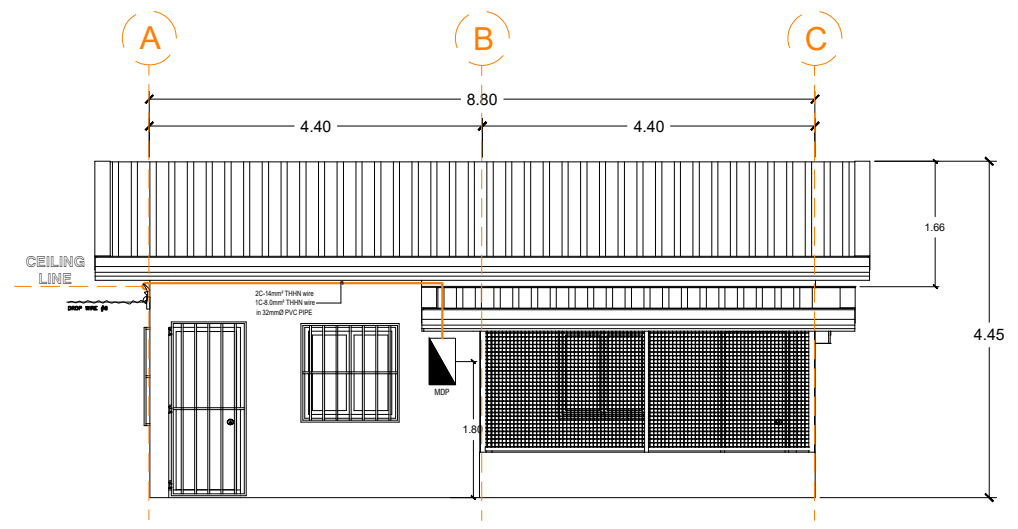

SERVICE ENTRANCE
SCALE

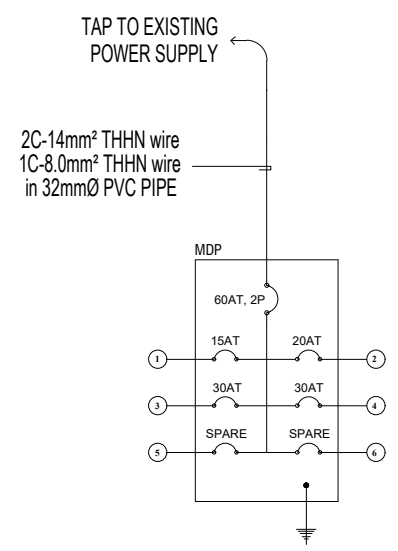

RISER DIAGRAM
NTS

CKT. NO.	LOAD DESCRIPTION	VA	V	A	SIZE OF WIRE	SIZE OF CONDUIT	CB RATING
1	10PCS-18watts PIN LIGHT	180	230	0.78	2-2.0mm ² THHN STRANDED CU. WIRE 1-2.0mm ² THHN STRANDED CU. WIRE	20mmØ uPVC PIPE PNS14	15 AT 2P
2	9PCS-POWER OUTLET	1620	230	7.04	2-3.5mm ² THHN STRANDED CU. WIRE 1-2.0mm ² THHN STRANDED CU. WIRE	20mmØ uPVC PIPE PNS14	20 AT 2P
3	AIRCON OUTLET 1HP	1840	230	8.00	2-5.5mm ² THHN STRANDED CU. WIRE 1-3.5mm ² THHN STRANDED CU. WIRE	20mmØ uPVC PIPE PNS14	30 AT 2P
4	AIRCON OUTLET 1HP	1840	230	8.00	2-5.5mm ² THHN STRANDED CU. WIRE 1-3.5mm ² THHN STRANDED CU. WIRE	20mmØ uPVC PIPE PNS14	30 AT 2P
5	SPARE	1500	230	6.52	-	-	-
6	SPARE	1500	230	6.52	-	-	-
TOTAL		8,480	230	36.87	-	-	-

$$I_T = \frac{8,480 \text{ VA} + (1,840 \text{ VA} \times 25\%)}{230 \text{ V}}$$

$$I_T = 38.87 \text{ AMP}$$

use: 60AT, 230V, 2POLE CIRCUIT BREAKER
2C-14mm² THHN wire
1C-8.0mm² THHN wire
in 32mmØ PVC PIPE

SCHEDULE OF LOAD
NTS

TO PUBLIC DRAINAGE

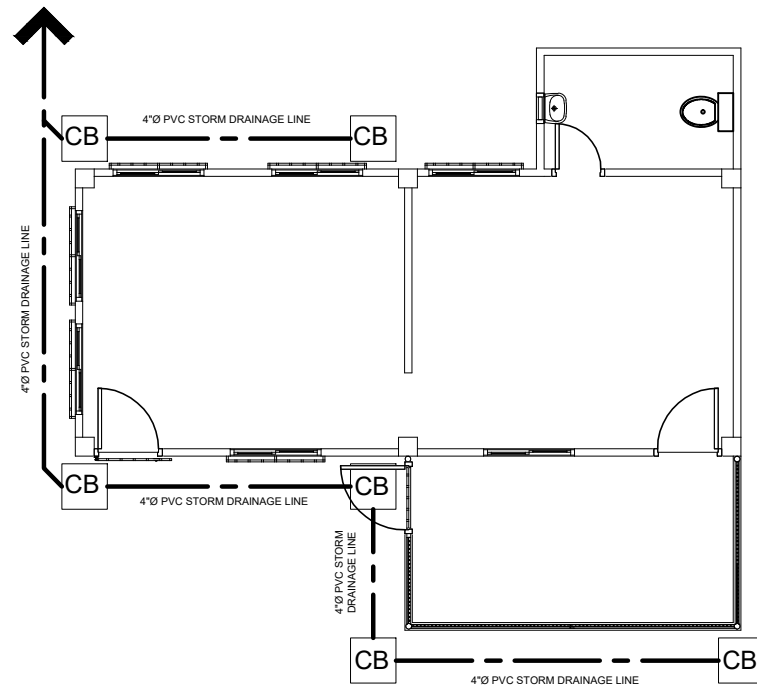

STORM WATER LINE LAYOUT PLAN
SCALE 1:100m

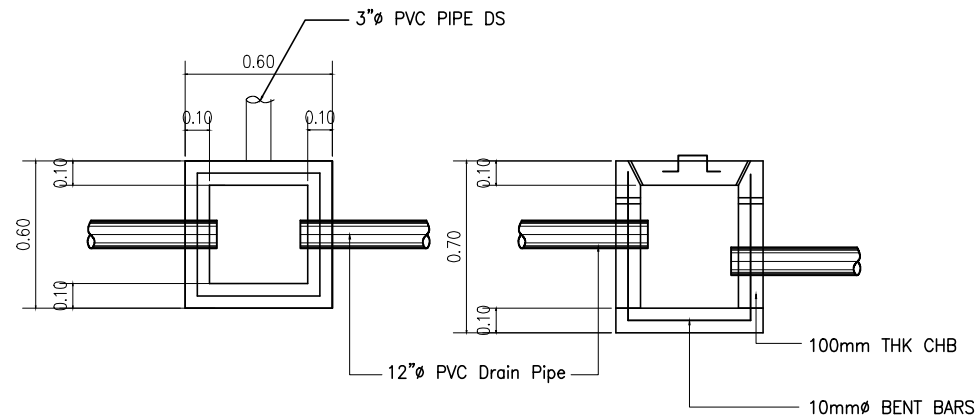

CATCH BASIN PLAN & SECTION

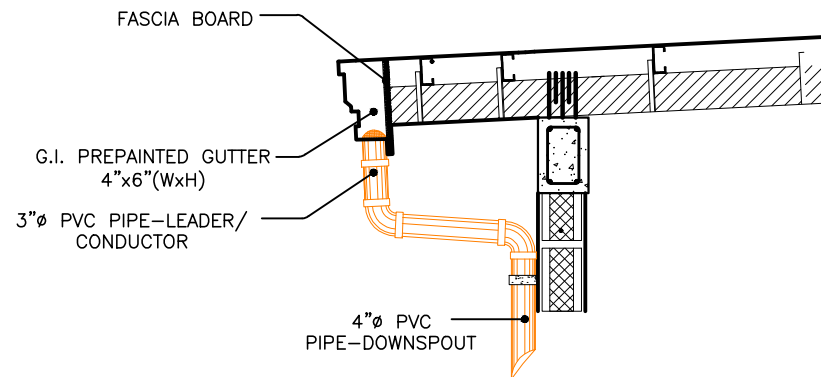

ROOF GUTTER DETAIL B

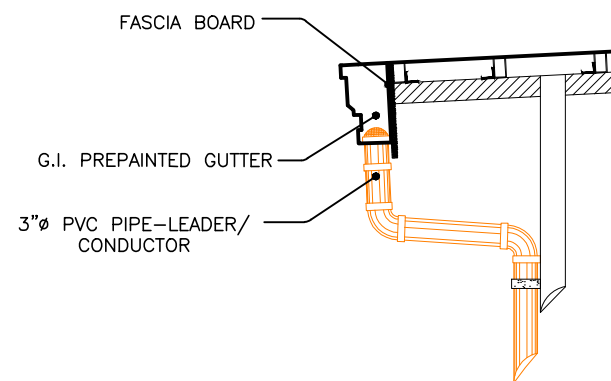

ROOF GUTTER DETAIL A

SPECIFICATIONS:

- 01) ALL SANITARY WORKS INCLUDE HEREIN SHALL BE EXECUTED ACCORDING TO THE PROVISIONS OF THE NATIONAL PLUMBING CODE OF THE PHILIPPINES, THE NATIONAL BUILDING CODE OF THE PHILIPPINES, AND ITS IMPLEMENTING RULES AND REGULATIONS.
- 02) COORDINATE THE DRAWING WITH OTHER RELATED DRAWINGS AND SPECIFICATIONS, THE ARCHITECT AND/OR ENGINEER SHALL BE NOTIFIED IMMEDIATELY OF ANY DISCREPANCY FOUND HEREIN, HIS/HER SHALL BE FINAL.
- 03) ALL PIPES SHALL BE INSTALLED AS INDICATED, ANY RELOCATION REQUIRED FOR PROPER EXECUTION OF OTHER TRADES SHALL BE WITH APPROVAL OF THE ARCHITECT AND OR ENGINEER.
- 04) PROPOSED SANITARY UTILITIES SHALL CONFORM TO THE ACTUAL LOCATION, DEPTH AND INVERT ELEVATION OF EXISTING PIPES AND STRUCTURES AS VERIFIED BY THE CONTRACTOR.
- 05) THE CONTRACTOR SHALL BE RESPONSIBLE FOR ALL REQUIRED FLOOR AND WALL OPENINGS.
- 06) ALL SLOPES FOR HORIZONTAL DRAINAGE SHALL BE MAINTAIN AT 2% AS MINIMUM UNLESS OTHERWISE NOTED.
- 07) SIZE OF WATER SUPPLY PIPES TO THE FIXTURES SHALL BE IN ACCORDANCE WITH THE MANUFACTURER'S INSTRUCTIONS.
- 08) ALL FIXTURE SHALL BE VENTED, UNLESS OTHERWISE NOTED.
- 09) THE WORK THROUGHOUT SHALL BE EXECUTED IN THE BEST AND MOST THROUGH MANNER KNOWN TO THE TRADE AND TO THE SATISFACTION OF THE ARCHITECT AND/OR ENGINEER.
- 10) THE CONTRACTOR SHALL VERIFY ALL EXISTING UTILITIES AT THE SITE AND COORDINATE THE WORKS WITH THE SEWER EFFLUENT DISPOSAL AND WATERLINE SERVICE CONNECTING POINT.
- 11) REFER TO THE TECHNICAL SPECIFICATION FOR DETAILED MATERIAL AND EQUIPMENT SPECIFICATION.

PLUMBING SYMBOLS			
⊙ DS	DOWNSPOUT	CB	CATCH BASIN
↘	SANITARY 45 DEG. ELBOW	—	STORM DRAINAGE LINE

REPUBLIC OF THE PHILIPPINES OFFICE OF THE CITY ENGINEER CITY OF NAGA	PROJECT TITLE PROPOSED IMPROVEMENT OF MULTI-PURPOSE BLDG	CHECKED BY: BRET OWEN S. TALAGTAG ENGINEER I	RECOMMENDED BY: EMMEL M. ADAQUE ENGINEER III	APPROVED BY: ALEXANDER N. CANING ACTING CITY ENGINEER	NELSON S. LEGACION CITY MAYOR	CAD BY: ALVAR RONALD A. PUNZALAN	SHEET NO. P1 P1
	LOCATION: JOLLY NEIGHBORS, BARANGAY DINAGA, NAGA CITY						

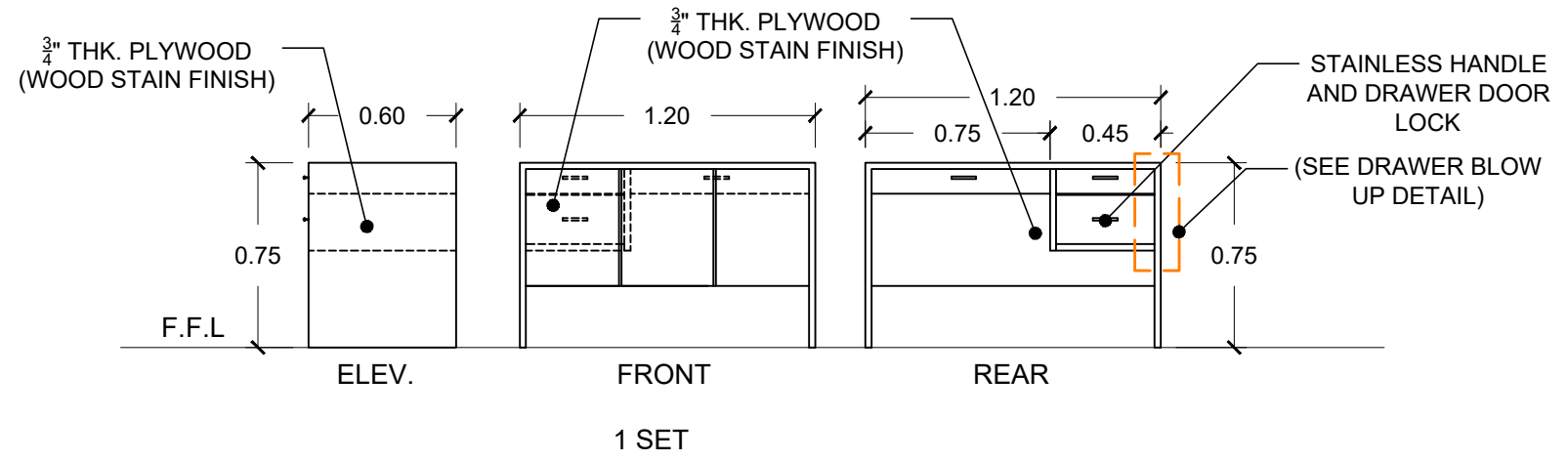
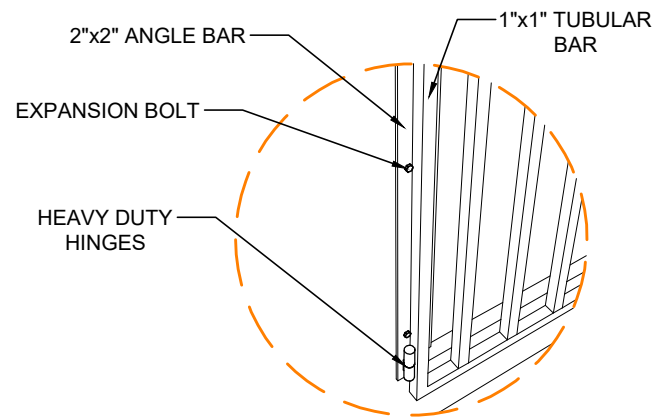
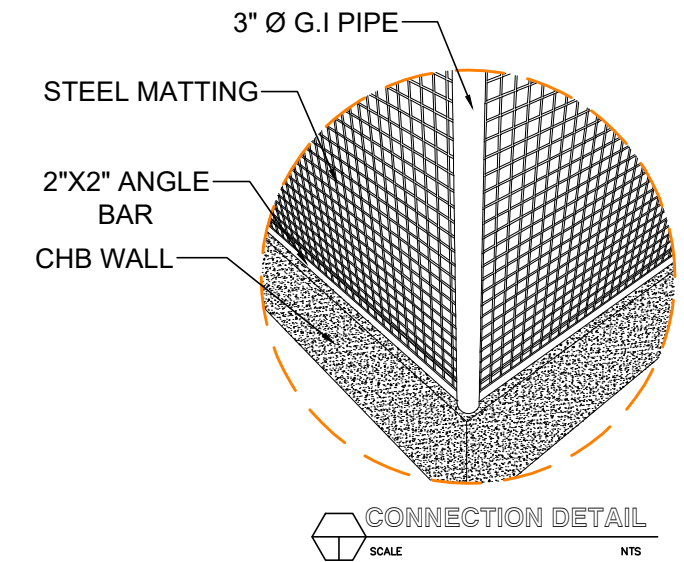
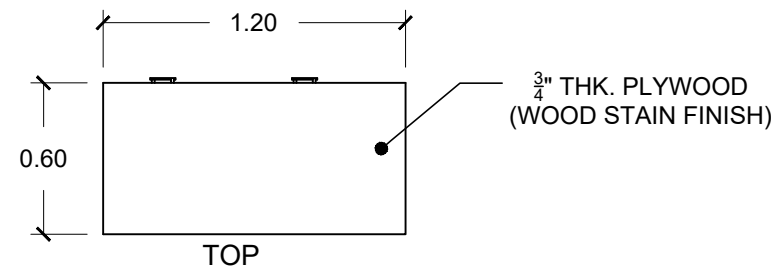
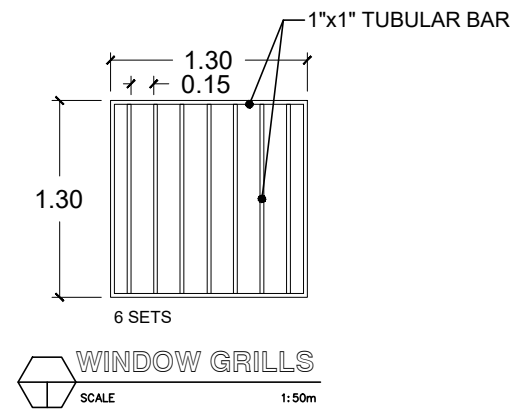
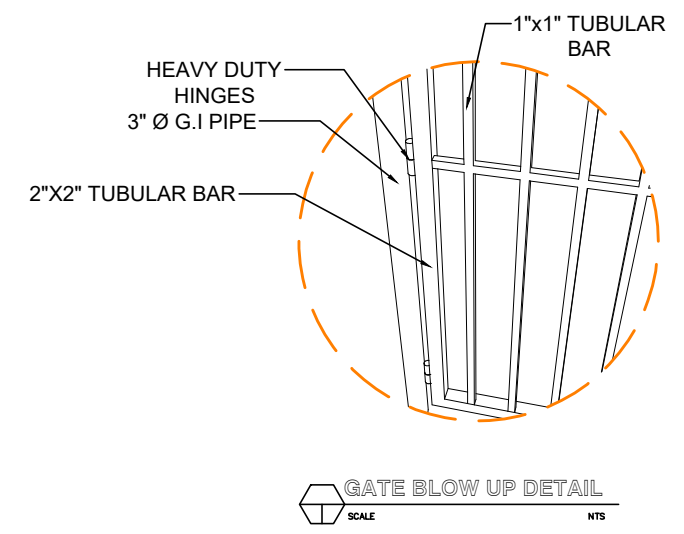
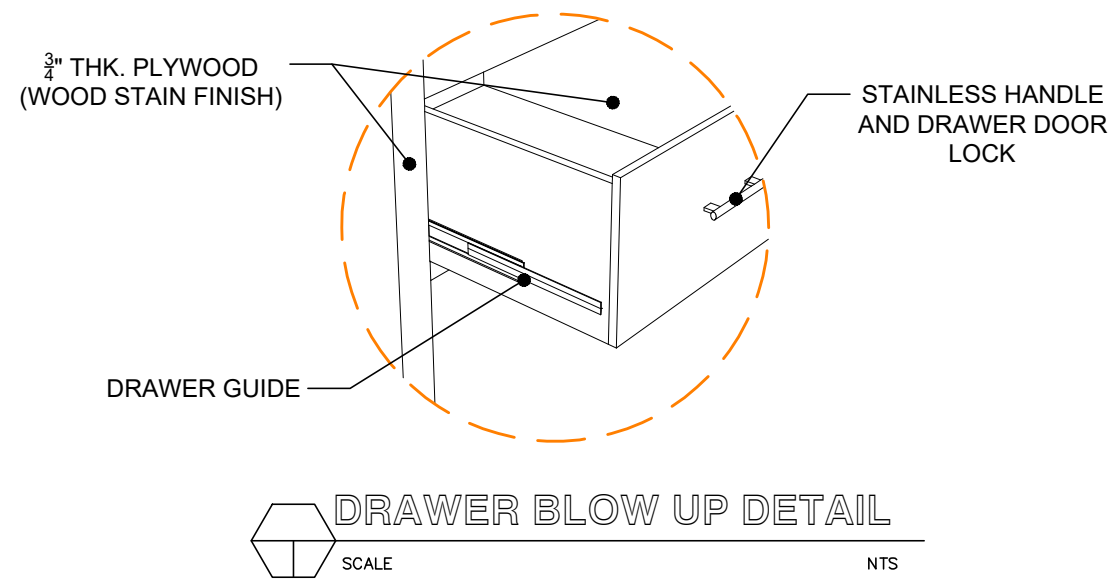
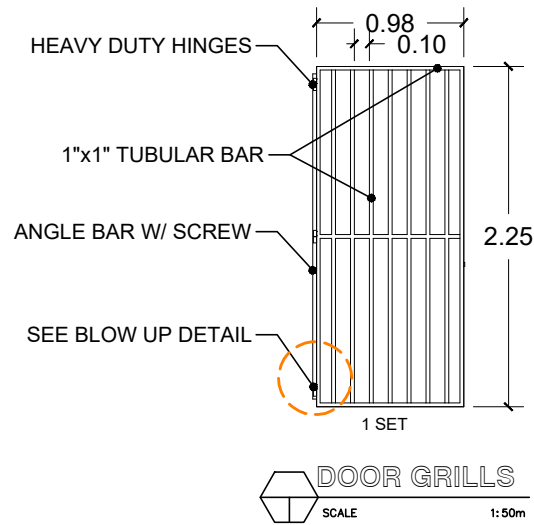

REPUBLIC OF THE PHILIPPINES OFFICE OF THE CITY ENGINEER CITY OF NAGA	PROJECT TITLE PROPOSED IMPROVEMENT OF MULTI-PURPOSE BLDG	CHECKED BY: BRET OWEN S. TALAGTAG ENGINEER I	RECOMMENDED BY: EMMEL M. ADAQUE ENGINEER III	APPROVED BY: ALEXANDER N. CANING ACTING CITY ENGINEER	NELSON S. LEGACION CITY MAYOR	CAD BY: ALVAR RONALD A. PUNZALAN	SHEET NO. S1 S3
	LOCATION: JOLLY NEIGHBORS, BARANGAY DINAGA, NAGA CITY						

DESIGN CRITERIA :

A. CONCRETE

$f_c' = 20.685 \text{ MPa}$ (3,000 psi), minimum compressive strength of concrete at 28 days unless otherwise specified.

B. REBAR

$f_y = 230 \text{ MPa}$ (33,000 psi), minimum yield strength of reinforcing bars unless otherwise specified.

C. STRUCTURAL STEEL

$F_y = 248 \text{ MPa}$ (36 ksi), specified minimum yield strength unless otherwise specified.

D. FOUNDATION

SBP = 95.706 KPa (2,000 psf), was used in the design for all footings. No footing shall rest on fill.

SPECIFICATIONS:
SOLAR PANEL: 250 WATTS
LUMENS: 25,000 LUMENS
BATTER CAPACITY: 3.2V 40AH
LAMP SIZE: 335x250x60mm
Quantity: 2 units

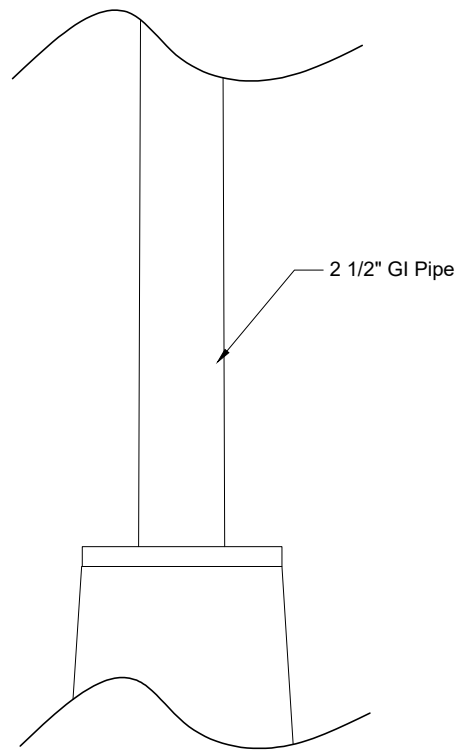

CONNECTION DETAILS
SCALE 1:10 M

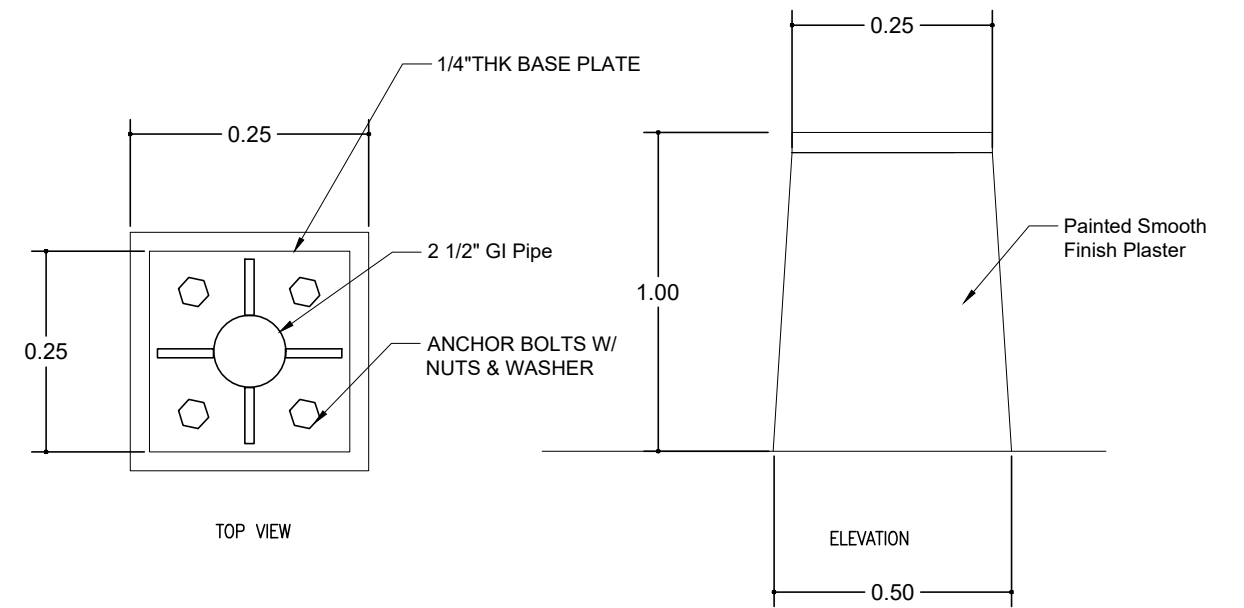

PEDESTAL DETAILS
SCALE 1:10 M

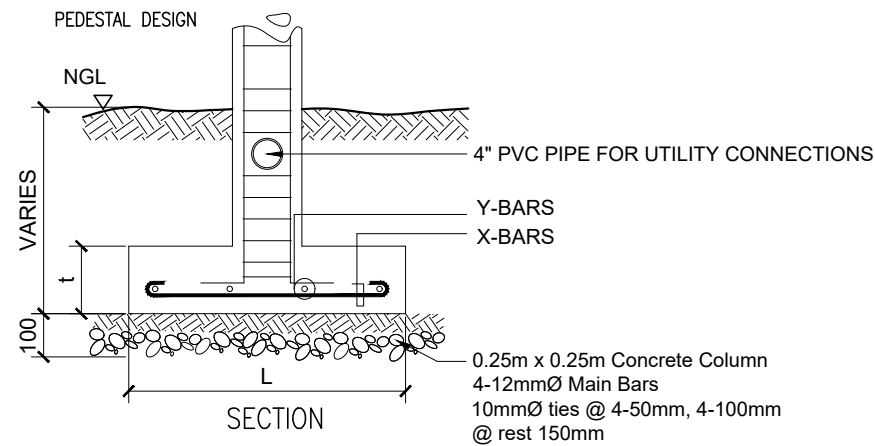
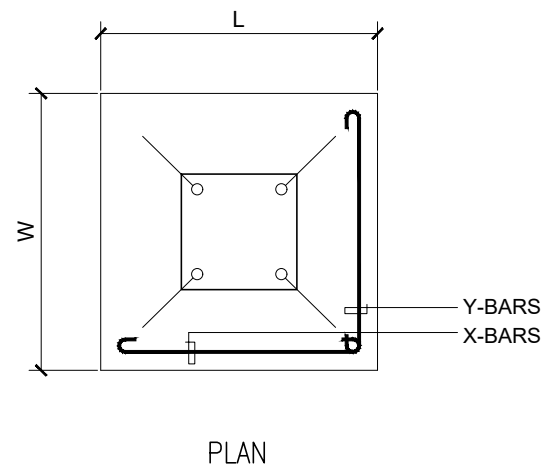

SCHEDULE OF FOOTINGS							
FOOTING MARK	FOOTING DIMENSIONS (mm)				REINFORCEMENT		REMARKS
	LENGTH (L)	WIDTH (W)	DEPTH (D)	THICKNESS (t)	BAR X	BAR Y	
F-1	800	800	800	250	4 - 12mm \emptyset	4 - 12mm \emptyset	SQUARE FOOTING

REPUBLIC OF THE PHILIPPINES OFFICE OF THE CITY ENGINEER CITY OF NAGA	PROJECT TITLE	CHECKED BY:	RECOMMENDED BY:	APPROVED BY:	CAD BY:	SHEET NO.
	PROPOSED IMPROVEMENT OF MULTI-PURPOSE BLDG LOCATION: JOLLY NEIGHBORS, BARANGAY DINAGA, NAGA CITY	BRET OWEN S. TALAGTAG ENGINEER I	EMMEL M. ADAQUE ENGINEER III	ALEXANDER N. CANING ACTING CITY ENGINEER	NELSON S. LEGACION CITY MAYOR	



BENCH REPAIR AND REPAINTING



FOR DEMOLITION
LOT 7 BLK. 12



FOR DEMOLITION
LOT 2 BLK. 13



BENCH REPAIR AND REPAINTING



BENCH REPAIR AND REPAINTING

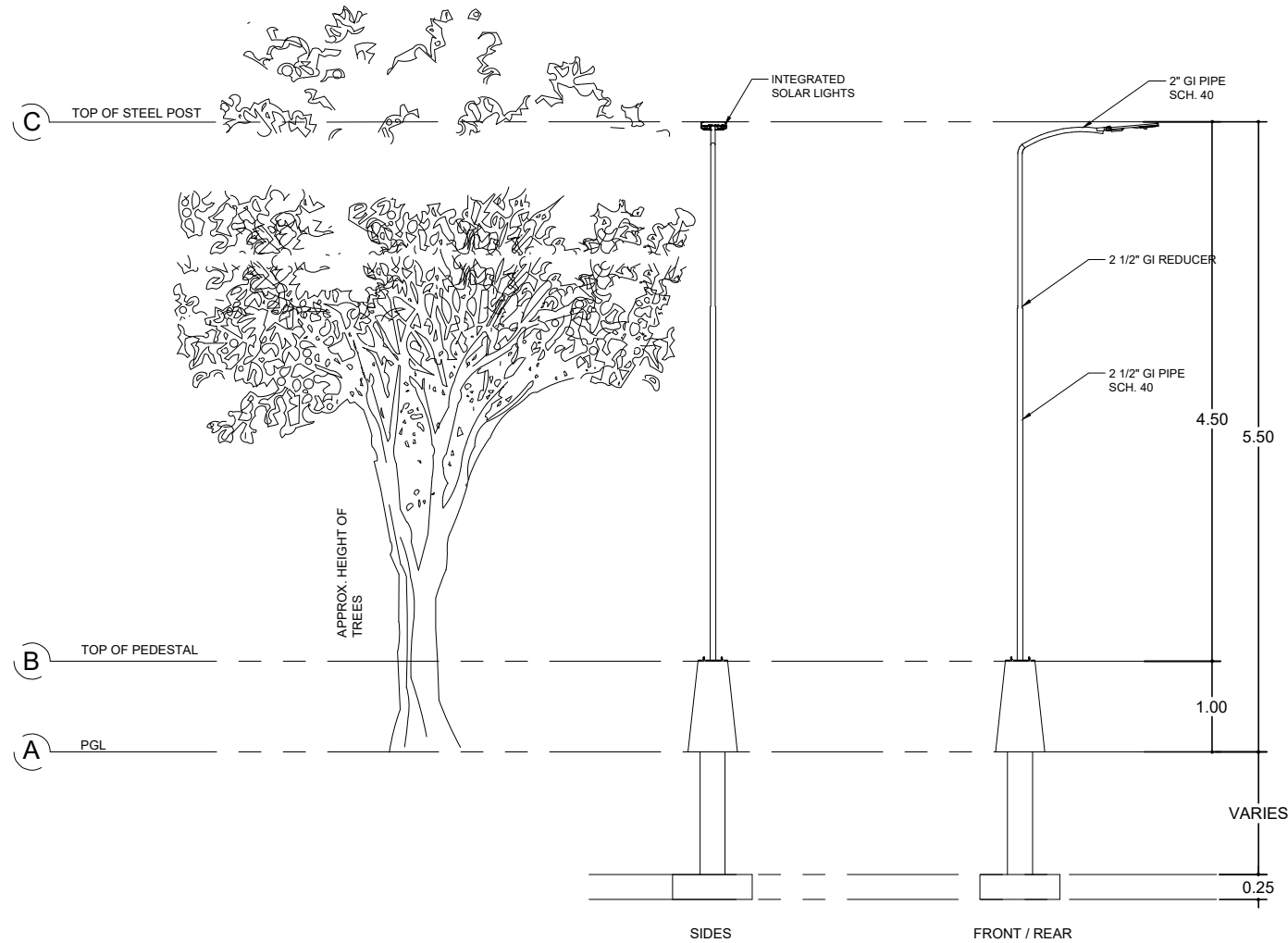

- LEGEND:**
- BENCH
 - SOLAR LIGHT
 - FOR DEMOLITION

 REPUBLIC OF THE PHILIPPINES OFFICE OF THE CITY ENGINEER CITY OF NAGA	PROJECT TITLE	CHECKED BY:	RECOMMENDED BY:	APPROVED BY:	CAD BY:	SHEET NO.	
	PROPOSED IMPROVEMENT OF MULTI-PURPOSE BLDG	BRET OWEN S. TALAGTAG ENGINEER I	EMMEL M. ADAQUE ENGINEER III	ALEXANDER N. CANING ACTING CITY ENGINEER	NELSON S. LEGACION CITY MAYOR		ALVIAR RONALD A. PUNZALAN
LOCATION: JOLLY NEIGHBORS, BARANGAY DINAGA, NAGA CITY							S ₃ S ₃

Section VIII. Bill of Quantities

BILL OF QUANTITIES

Name of Project and Location		Improvement of MP Building, Jolly Neighbors, Bgy. Sta. Cruz			
Contract Reference Number		009343-2024-04			
Approved Budget for the Contract (ABC)		P 480,000.00			
Contract Duration		60 calendar days			
Equipment Required		Welding Machine			
Item No.	Description	Quantity	Unit	Unit Price (in pesos)	Amount (in pesos)
100 C	Clearing and Removal Works	1.00	Lot		
SPL012C	Roofing and Ceiling	5.40	Sq.M.		
SPL016C	Tile Works	33.44	Sq.M.		
SPL131A	Extension	13.05	Sq.M.		
NRTB 9	Electrical Works	33.54	Sq.M.		
SPL243	Carpentry Works	1.44	Sq.M.		
SPL049A	Catch Basins	6.00	Units		
SPL 320A	Solar Street Lights	2.00	Units		
NRTB 8	Painting Works	173.54	Sq.M.		
SPL718B	Steel Grills and Steel Gate	12.34	Sq.M.		
SPLH86	Repair of Bench	5.00	Sq.M.		
SPL001	Sign Board	1.00	Pc.		
T O T A L					
Total Amount in Words:					

Submitted by:

Name & Signature of Bidder's Representative:

Position:

Name of Bidder:

D a t e:

Section IX. Checklist of Technical and Financial Documents

Checklist of Technical and Financial Documents

I. TECHNICAL COMPONENT ENVELOPE

Class "A" Documents

Legal Documents

- (a) Valid PhilGEPS Registration Certificate (Platinum Membership) (all pages) in accordance with Section 8.5.2 of the IRR;

Technical Documents

- (b) Statement of the prospective bidder of all its ongoing government and private contracts, including contracts awarded but not yet started, if any, whether similar or not similar in nature and complexity to the contract to be bid; **and**
- (c) Statement of the bidder's Single Largest Completed Contract (SLCC) similar to the contract to be bid, except under conditions provided under the rules; **and**
- (d) Special PCAB License in case of Joint Ventures**and** registration for the type and cost of the contract to be bid; **and**
- (e) Original copy of Bid Security. If in the form of a Surety Bond, submit also a certification issued by the Insurance Commission**or** original copy of Notarized Bid Securing Declaration; **and**
- (f) Project Requirements, which shall include the following:
 - a. Organizational chart for the contract to be bid;
 - b. List of contractor's key personnel (e.g., Project Manager, Project Engineers, Materials Engineers, and Foremen), to be assigned to the contract to be bid, with their complete qualification and experience data;
 - c. List of contractor's major equipment units, which are owned, leased, and/or under purchase agreements, supported by proof of ownership or certification of availability of equipment from the equipment lessor/vendor for the duration of the project, as the case may be;**and**
- (g) Original duly signed Omnibus Sworn Statement (OSS)**and** if applicable, Original Notarized Secretary's Certificate in case of a corporation, partnership, or cooperative; or Original Special Power of Attorney of all members of the joint venture giving full power and authority to its officer to sign the OSS and do acts to represent the Bidder.

Financial Documents

- (h) The prospective bidder's computation of Net Financial Contracting Capacity (NFCC).

Class “B” Documents

- (i) If applicable, duly signed joint venture agreement (JVA) in accordance with RA No. 4566 and its IRR in case the joint venture is already in existence **or** duly notarized statements from all the potential joint venture partners stating that they will enter into and abide by the provisions of the JVA in the instance that the bid is successful.

II. FINANCIAL COMPONENT ENVELOPE

- (j) Original of duly signed and accomplished Financial Bid Form; **and**

Other documentary requirements under RA No. 9184

- (k) Original of duly signed Bid Prices in the Bill of Quantities; **and**
- (l) Duly accomplished Detailed Estimates Form, including a summary sheet indicating the unit prices of construction materials, labor rates, and equipment rentals used in coming up with the Bid; **and**
- (m) Cash Flow by Quarter.

FORMS

Bid Form for the Procurement of Infrastructure Projects

Date : _____

Project/Contract Identification No. : _____

To: **CITY GOVERNMENT OF NAGA**
City Hall Compound, J. Miranda Avenue
Concepcion Pequena, Naga City

Having examined the Philippine Bidding Documents (PBDs) including the Supplemental or Bid Bulletin Numbers _____ [insert numbers], the receipt of which is hereby duly acknowledged, we, the undersigned, declare that:

- a. We have no reservation to the PBDs, including the Supplemental or Bid Bulletins, for the Procurement Project: _____ [insert name of contract];
- b. We offer to execute the Works for this Contract in accordance with the PBDs;
- c. The total price of our Bid in words and figures, excluding any discounts offered below is: _____ (P _____) Pesos [insert information];
- d. The discounts offered and the methodology for their application are: _____ [insert information];
- e. The total bid price includes the cost of all taxes, such as, but not limited to: [specify the applicable taxes, e.g. (i) value added tax (VAT), (ii) income tax, (iii) local taxes, and (iv) other fiscal levies and duties], which are itemized herein and reflected in the detailed estimates,
- f. Our Bid shall be valid within the a period stated in the PBDs, and it shall remain binding upon us at any time before the expiration of that period;
- g. If our Bid is accepted, we commit to obtain a Performance Security in the amount of _____ (P _____) Pesos [insert percentage amount]percent of the Contract Price for the due performance of the Contract, or a Performance Securing Declaration in lieu of the the allowable forms of Performance Security, subject to the terms and conditions of issued GPPB guidelines for this purpose;
- h. We are not participating, as Bidders, in more than one Bid in this bidding process, other than alternative offers in accordance with the Bidding Documents;
- i. We understand that this Bid, together with your written acceptance thereof included in your notification of award, shall constitute a binding contract between us, until a formal Contract is prepared and executed; and
- j. We understand that you are not bound to accept the Lowest Calculated Bid or any other Bid that you may receive.

- k. We likewise certify/confirm that the undersigned, is the duly authorized representative of the bidder, and granted full power and authority to do, execute and perform any and all acts necessary to participate, submit the bid, and to sign and execute the ensuing contract for the

[Name of Project] of the City Government of Naga.

1. We acknowledge that failure to sign each and every page of this Bid Form, including the Bill of Quantities, shall be a ground for the rejection of our bid.

Name: _____

Legal Capacity: _____

Signature: _____

Duly authorized to sign the Bid for and behalf of: _____

Date: _____

Omnibus Sworn Statement

REPUBLIC OF THE PHILIPPINES)
CITY OF NAGA) S.S.

AFFIDAVIT

I, _____, of legal age, _____ [Civil Status], _____
[Nationality], and residing at _____, after
having been duly sworn in accordance with law, do hereby depose and state that:

1. [If a sole proprietorship:] I am the sole proprietor or authorized representative of
_____ with office address at
_____;

[If a partnership, corporation, cooperative, or joint venture:] I am the duly authorized and
designated representative of _____ with
office address at _____;

2. [If a sole proprietorship:] As the owner and sole proprietor, or authorized representative of
_____, I have full power and authority to do, execute
and perform any and all acts necessary to participate, submit the bid, and to sign and execute the
ensuing contract for _____ of the City Government of
Naga, as shown in the attached duly notarized Special Power of Attorney;

[If a partnership, corporation, cooperative, or joint venture:] I am granted full power and authority
to do, execute and perform any and all acts necessary to participate, submit the bid, and to sign
and execute the ensuing contract for _____ of the City
Government of Naga, as shown in the attached _____
[state title of attached document showing proof of authorization (e.g., duly notarized Secretary's
Certificate, Board/Partnership Resolution, or Special Power of Attorney, whichever is
applicable)];

3. _____ is not "blacklisted" or barred from
bidding by the Government of the Philippines or any of its agencies, offices, corporations, or Local
Government Units, foreign government/foreign or international financing institution whose
blacklisting rules have been recognized by the Government Procurement Policy Board, by itself or
by relation, membership, association, affiliation, or controlling interest with another blacklisted
person or entity as defined and provided for in the Uniform Guidelines on Blacklisting;

4. Each of the documents submitted in satisfaction of the bidding requirements is an authentic
copy of the original, complete, and all statements and information provided therein are true and
correct;

5. _____ is authorizing the Head of the
Procuring Entity or its duly authorized representative(s) to verify all the documents submitted;

6. [If a sole proprietorship:] The owner or sole proprietor is not related to the Head of the
Procuring Entity, members of the Bids and Awards Committee (BAC), the Technical Working
Group, and the BAC Secretariat, the head of the Project Management Office or the end-user unit,
and the project consultants by consanguinity or affinity up to the third civil degree;

[If a partnership or cooperative:]None of the officers and members of _____ is related to the Head of the Procuring Entity, members of the Bids and Awards Committee (BAC), the Technical Working Group, and the BAC Secretariat, the head of the Project Management Office or the end-user unit, and the project consultants by consanguinity or affinity up to the third civil degree;

[If a corporation or joint venture:] None of the officers, directors, and controlling stockholders of _____ is related to the Head of the Procuring Entity, members of the Bids and Awards Committee (BAC), the Technical Working Group, and the BAC Secretariat, the head of the Project Management Office or the end-user unit, and the project consultants by consanguinity or affinity up to the third civil degree;

7. _____ complies with existing labor laws and standards; and
8. _____ is aware of and has undertaken the responsibilities as a Bidder in compliance with the Philippine Bidding Documents, which includes:
 - a. Carefully examining all of the Bidding Documents;
 - b. Acknowledging all conditions, local or otherwise, affecting the implementation of the Contract;
 - c. Making an estimate of the facilities available and needed for the contract to be bid, if any; and
 - d. Inquiring or securing Supplemental/Bid Bulletin(s) issued for the _____.
9. _____ did not give or pay directly or indirectly, any commission, amount, fee, or any form of consideration, pecuniary or otherwise, to any person or official, personnel or representative of the government in relation to any procurement project or activity.
10. In case advance payment was made or given, failure to perform or deliver any of the obligations and undertakings in the contract shall be sufficient grounds to constitute criminal liability for Swindling (Estafa) or the commission of fraud with unfaithfulness or abuse of confidence through misappropriating or converting any payment received by a person or entity under an obligation involving the duty to deliver certain goods or services, to the prejudice of the public and the government of the Philippines pursuant to Article 315 of Act No. 3815 s. 1930, as amended, or the Revised Penal Code.

IN WITNESS WHEREOF, I have hereunto set my hand this _____ day of _____, 20____ at Naga City, Philippines.

Name of Bidder or its Authorized Representative

Signatory's legal capacity

Affiant

SUBSCRIBED AND SWORN to before me this ____ day of _____, 20____ [month] [year] at _____ [place of execution], Philippines. Affiant/s is/are personally known to me and was/were identified by me through competent evidence of identity as defined in the 2004 Rules on Notarial Practice (A.M. No. 02-8-13-SC). Affiant/s exhibited to me his/her _____ [insert type of government identification card used], with his/her photograph and signature appearing thereon, with no. _____ and his/her Community Tax Certificate No. _____ issued on _____ at _____.

Witness my hand and seal this ____ day of _____, 20____ [month] [year].

REPUBLIC OF THE PHILIPPINES)
CITY OF NAGA) S.S.

BID SECURING DECLARATION

Project/Contract Identification No.: _____

To: CITY GOVERNMENT OF NAGA
City Hall Compound, J. Miranda Avenue
Concepcion Pequena, Naga City

I/We, the undersigned, declare that:

1. I/We understand that, according to your conditions, bids must be supported by a Bid Security, which may be in the form of a Bid Securing Declaration.

2. I/We accept that: (a) I/we will be automatically disqualified from bidding for any procurement contract with any procuring entity for a period of two (2) years upon receipt of your Blacklisting Order; and, (b) I/we will pay the applicable fine provided under Section 6 of the Guidelines on the Use of Bid Securing Declaration, within fifteen (15) days from receipt of the written demand by the procuring entity for the commission of acts resulting to the enforcement of the bid securing declaration under Sections 23.1(b), 34.2, 40.1 and 69.1, except 69.1(f), of the IRR of RA No. 9184; without prejudice to other legal action the government may undertake.

3. I/We understand that this Bid Securing Declaration shall cease to be valid on the following circumstances:

- a) Upon expiration of the bid validity period, or any extension thereof pursuant to your request;
- b) I am/we are declared ineligible or post-disqualified upon receipt of your notice to such effect, and (i) I/we failed to timely file a request for reconsideration or (ii) I/we filed a waiver to avail of said right; and
- c) I am/we are declared the bidder with the Lowest Calculated Responsive Bid, and I/we have furnished the performance security and signed the Contract.

IN WITNESS WHEREOF, I/We have hereunto set my/our hand/s this ____ day of _____ [month], _____ [year] at _____ [place of execution].

Name of Bidder or its Authorized Representative

Signatory's legal capacity

Affiant

SUBSCRIBED AND SWORN to before me this ____ day of _____, 20____ [month] [year] at _____ [place of execution], Philippines. Affiant/s is/are personally known to me and was/were identified by me through competent evidence of identity as defined in the 2004 Rules on Notarial Practice (A.M. No. 02-8-13-SC). Affiant/s exhibited to me his/her

_____ [insert type of government identification card used], with his/her photograph and signature appearing thereon, with no. _____ and his/her Community Tax Certificate No. _____ issued on _____ at _____.

Witness my hand and seal this _____ day of _____, 20____ [month] [year].

STATEMENT OF THE BIDDER'S SINGLE LARGEST COMPLETED CONTRACT (SLCC)

(similar to the contract to be bid, in accordance with ITB Clause 5.4)

Business Name: _____
 Business Address: _____

Name of Contract	Date of Contract	Contract Duration	Owner's Name and Address	Nature of Work	Contractor's Role (sole contractor, subcontractor or partner in a JV) and percentage of participation	Contract Value at Award	Estimated Completion Time	Percentage of Planned and Actual Accomplishments	Value of Outstanding Works
GOVERNMENT									
PRIVATE									

Note: This statement shall be supported with: 1. Notice of Award and/or Notice to Proceed, 2. Project Owner's Certificate of Final Acceptance issued by the Owner other than the Contractor or the Constructors Performance Evaluation System (CPES) Final Rating, which must be at least satisfactory

Submitted by:

 Name & Signature of Authorized Representative

 Designation

 Date

STATEMENT OF ALL ONGOING GOVERNMENT AND PRIVATE CONTRACTS

(including contracts awarded but not yet started, if any, whether similar or not similar in nature and complexity to the contract to be bid)

Business Name: _____
 Business Address: _____

Name of Contract	Date of Contract	Contract Duration	Owner's Name and Address	Nature of Work	Contractor's Role (sole)	Contract Value at	Estimated Completion	Percentage of Planned	Value of Outstanding
GOVERNMENT									
PRIVATE									

Note: This statement shall be supported with: 1. Notice of Award and/or Contract; 2. Notice to Proceed, 3. Certificate of Accomplishment signed by the owner or authorized representative

Submitted by:

 Name & Signature of Authorized Representative

 Designation

 Date

NOTE:

- **PLEASE USE THE FORMS PROVIDED IN THIS PBD AND SHOULD REMAIN UNALTERED.**
- **KINDLY PUT TABS AT THE RIGHT SIDE OF ALL THE DOCUMENTARY REQUIREMENTS.**

